

ruchelman

corporate  
international  
taxation



# INSIGHTS

---

**O.E.C.D. DISCUSSION DRAFTS ISSUED REGARDING B.E.P.S. ACTION 2 – NEUTRALIZING THE EFFECTS OF HYBRID MISMATCH ARRANGEMENTS**

**THE O.E.C.D.'S APPROACH TO B.E.P.S. CONCERNS RAISED BY THE DIGITAL ECONOMY**

**WHAT MUST FOREIGN TRUSTS AND FAMILY CORPORATIONS DO ABOUT F.A.T.C.A.?**

**TRANSFER PRICING – BANKRUPTCY COURT PREVENTS I.R.S. FROM PURSUING UNSUPPORTED TRANSFER PRICING CLAIMS**

**CORPORATE MATTERS:  
SHAREHOLDER AGREEMENTS**

**AND MORE**

Insights Vol. 1 No. 3

## TABLE OF CONTENTS

### Editors' Note

O.E.C.D. Discussion Drafts Issued Regarding B.E.P.S. Action 2 – Neutralizing the Effects of Hybrid Mismatch Arrangements.....3

The O.E.C.D.'s Approach to B.E.P.S. Concerns Raised by the Digital Economy.....17

What Must Foreign Trusts and Family Corporations do about F.A.T.C.A.?.....20

Transfer Pricing – Bankruptcy Court Prevents I.R.S. from Pursuing Unsupported Transfer Pricing Claims.....22

Tax 101: Financing A U.S. Subsidiary – Debt vs. Equity.....27

Corporate Matters: Shareholder Agreements .....33

New York State Makes Major Changes to Estate and Gift Tax Law.....37

U.S. Tax Treaty Update....39

Updates and Other Tidbits.....40

### In The News

### About Us & Contacts

## EDITORS' NOTE

In this month's edition of *Insights*, we highlight a number of recent developments in the O.E.C.D. B.E.P.S. project and F.A.T.C.A., among other topics:

- **Discussion Drafts on B.E.P.S.** Three O.E.C.D. public discussion drafts were published in March. Two address hybrid mismatch arrangements designed to exploit a difference in the characterization of an entity or an arrangement under the laws of two or more tax jurisdictions. A third provides a detailed introduction to the digital economy and proposes that rules to prevent B.E.P.S. approaches should be consistent with counterparts in the traditional economy.
- **F.A.T.C.A. for Foreign Trusts and Family Corporations.** After years of preparation, F.A.T.C.A. will soon become effective, but with recent revisions to I.R.S. regulations and careful planning, certain entities may be subject to fewer reporting requirements.
- **Recent Developments in Transfer Pricing.** A finding by the U.S. Bankruptcy Court raises questions of I.R.S. accountability in seeking adjustments of tax on transfer pricing audits and provides practical guidance on the pricing of a controlled transaction.
- **Tax 101 – Debt vs. Equity.** We address the basic rules under which internal financing within a multinational group will be judged as true debt or disguised equity for U.S. tax purposes. The focus is on foreign-owned U.S. subsidiary borrowing from a related party outside the U.S.
- **Corporate Matters – Shareholder Agreements.** We discuss what to look for in a shareholders agreement and how to identify potential issues – and to eliminate them with proper drafting – in order to avoid costly litigation.
- **State and Local Taxation – New York.** With the release of new legislation, N.Y.S. had made significant changes to its Estate and Gift Tax rules, including increased basic exclusion amounts for filing an estate tax return, new treatment of gifts and ING trusts.
- **Revised U.S. Tax Treaties.** We summarize treaty revisions recently approved by the Senate Foreign Relations committee.

We hope you enjoy this issue.

-The Editors

# O.E.C.D. DISCUSSION DRAFTS ISSUED REGARDING BEPS ACTION 2 – NEUTRALIZING THE EFFECTS OF HYBRID MISMATCH ARRANGEMENTS

**Author**  
Stanley C. Ruchelman

**Tags**  
B.E.P.S.  
O.E.C.D.  
Double Deduction

## INTRODUCTION

On March 19, 2014, the O.E.C.D. issued two discussion drafts proposing steps to neutralize abusive tax planning through hybrid mismatch arrangements. One report proposed changes in domestic law;<sup>1</sup> the second proposed changes to the O.E.C.D. Model Tax Convention.<sup>2</sup>

The discussion drafts reflect the O.E.C.D.’s attempt to bring “zero-sum game” concepts to global tax planning. In a zero-sum game, transactions between two or more parties must always equal zero (*i.e.*, if one party to a transaction recognizes positive income of “X” and pays tax on that amount, the other party or parties generally must recognize negative income of the same amount, thereby reducing tax to the extent permitted under law). Seen from the viewpoint of the government, tax revenue is neither increased nor decreased on a macro basis if timing differences are disregarded.

If all transactions are conducted within one jurisdiction, the government is the ultimate decision maker as to the exceptions to the zero-sum analysis. For policy reasons, a government may decide to make an exception to a zero-sum game result by allowing the party reporting positive income to be taxed at preferential rates or not at all, while allowing the party reporting negative income to fully deduct its payment. But, when transactions cross borders and involve related parties, taxpayers have a say in what is taxed and what is not taxed.

From a global tax revenue perspective, the transaction can move from a zero-sum to a double negative sum in a way that is fully compliant with the laws of each country. Tax advisers receive bonuses when these results are achieved and investors applaud. The O.E.C.D. views this as abusive and proposes changes in domestic law and income tax treaties to end the practice.

---

<sup>1</sup> See <http://www.oecd.org/ctp/aggressive/hybrid-mismatch-arrangements-discussion-draft-domestic-laws-recommendations-march-2014.pdf>.

<sup>2</sup> See <http://www.oecd.org/ctp/treaties/hybrid-mismatch-arrangements-discussion-draft-treaty-issues-march-2014.pdf>.

# DOMESTIC LAW PROPOSALS

Hybrid mismatch arrangements incorporate techniques that exploit a difference in the characterization of an entity or an arrangement under the laws of two or more tax jurisdictions to produce a mismatch in tax outcomes. The B.E.P.S. Action Plan calls for the adoption of domestic rules that are designed to put an end to these arrangements.

Three mismatch arrangements are targeted by the proposal. They are: (a) hybrid financial instrument, (b) hybrid entity payments, and (c) reverse hybrid and imported mismatch arrangements. Those advisers who regularly plan for cross-border mergers, acquisitions, and financings should be familiar with each planning technique.

## Hybrid Financial Instruments

These are transactions where a payment is made under a financial instrument. The payor claims a deduction in its jurisdiction of residence, but payment is not subject to withholding tax, and the related recipient is treated in its jurisdiction of residence as if no taxable income is received.

A simplified mismatch arrangement is illustrated by the following diagram:

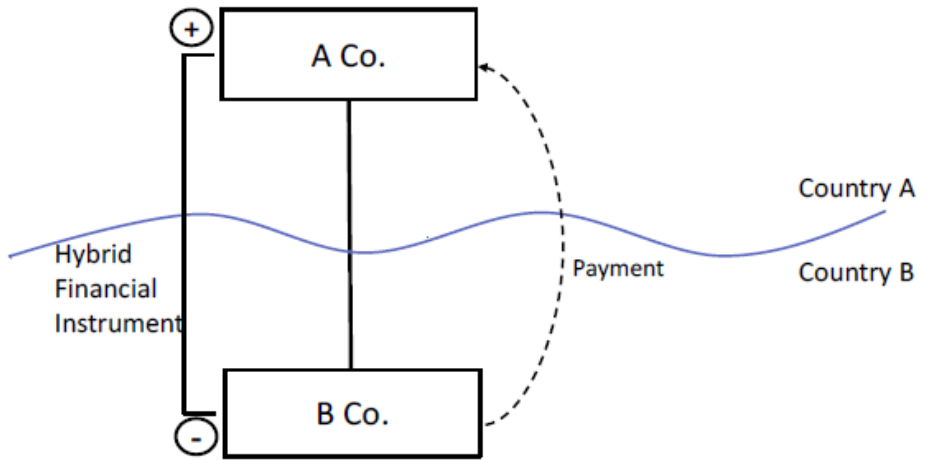

In the illustration, B Co. (an entity resident in Country B) issues a hybrid financial instrument to A Co. (an entity resident in Country A). The instrument is treated as debt for the purposes of Country B law, and Country B grants a deduction for interest payments made under the instrument, while Country A law grants some form of tax relief (an exemption, exclusion, indirect tax credit, etc.) in relation to the interest payments received under that instrument. Hence, the zero-sum game result is disrupted.

The mismatch may be due to any of several reasons. Most commonly the financial instrument is treated by the issuer as debt (which is a claim against the issuer) and by the holder as equity (which is an investment in the issuer). This difference in characterization can result in a payment that is treated as a deductible by the issuer and a dividend by the recipient. If the recipient is entitled to a dividends-received

deduction or the dividend corresponds with the entity's foreign tax credit planning, no tax is imposed on the recipient or it may reduce tax otherwise due on global income through the maximization of credits. Again, implicit in the proposal is the exemption from withholding tax allowed when payment is made.

Other planning techniques may result in the mismatch of tax outcomes. These techniques may result from specific differences in the tax treatment of a particular payment made under the instrument. Examples include:

- A subscription or sale of shares with a deferred purchase price component that is treated as giving rise to a deductible expense for the share subscriber and a non-taxable receipt for the share issuer;
- A deduction claimed by an issuer for the premium paid on converting a mandatory convertible note, while the holder of the note treats the premium as an exempt gain;
- An issuer that claims a deduction for the value of an embedded option in an optional convertible note, while the holder ignores the value of the option component (or gives it a lower value than the issuer);
- An issuer that bifurcates an interest-free shareholder loan into its equity and debt components and then accrues the equity component over the life of the loan, while the holder treats the entire amount as a loan for the principal sum.

Hybrid transfers are often cast as collateralized loan arrangements or derivative transactions where the counterparties to the same arrangement are located in different jurisdictions and each treats itself as the owner of the loan collateral or the subject matter of the derivative. A typical example is a sale and repurchase arrangement (generally referred to as a "repo") where the terms of the repo make it the economic equivalent of a collateralized loan. Nonetheless, one jurisdiction treats the arrangement in accordance with its form (a sale and a repurchase of the asset), while the counterparty jurisdiction taxes the arrangement in accordance with its economic substance (a loan with the asset serving as collateral). This is illustrated in the following diagram:

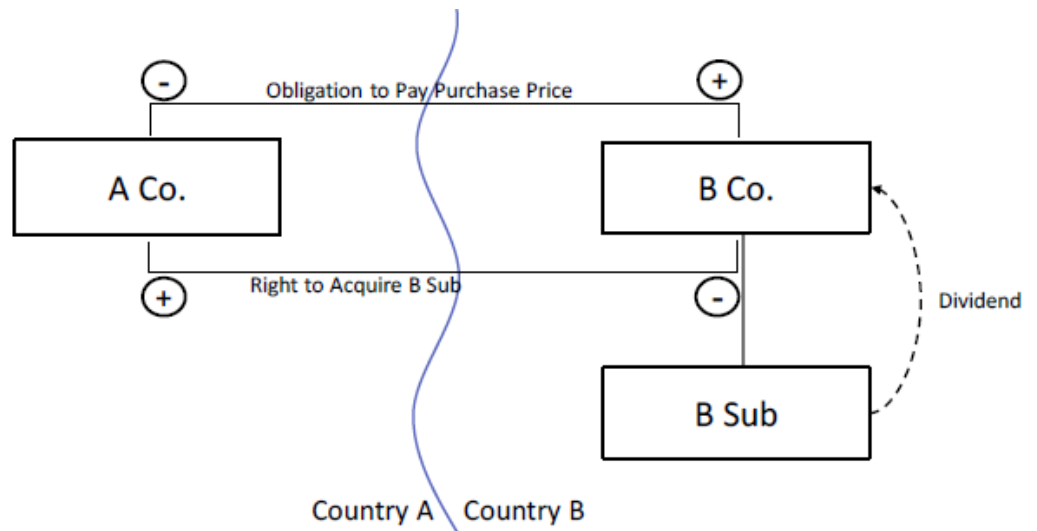

In the example, a company in Country A (A Co.) owns a subsidiary (B Sub). A Co. sells the shares of B Sub (or a class of shares in B Sub) to B Co. under an arrangement that calls upon A Co. (or an affiliate) to acquire those shares at a future date for an agreed price. Between the sale and repurchase, B Sub earns income, pays tax, and makes distributions on the shares to B Co.

Country B taxes the arrangement in accordance with its form. Accordingly, B Co. is treated as the owner of the B Sub shares and entitled to receive and retain the dividends paid by B Sub during the life of the repo. Country B will typically grant a credit, exclusion, exemption or some other tax relief to B Co. on the dividends received. B Co. also treats the transfer of the shares back to A Co. as a genuine sale of shares and may exempt any gain on disposal under an equity participation exemption or a general exclusion for capital gains.

In accordance with its economic substance, for Country A tax purposes, the transaction is treated as a loan by B Co. to A Co. that is secured through a pledge of shares in B Sub and effected through a temporary transfer of legal title. A Co. is thus regarded as being the owner of the B Sub shares with the corresponding entitlement to B Sub dividends during the life of the repo.

Because Country A treats A Co. as the owner of B Sub shares, it requires A Co. to include in its income the amount of any dividends paid by B Sub to B Co. However the income tax on dividends will generally be sheltered by a credit, exclusion, or other tax relief applicable to those dividends under the laws of Country A. The net cost of the repo to A Co. is treated as a deductible financing cost. This cost includes the dividends treated as economically derived by A Co. (which are paid to and retained by B Co. from B Sub), but for Country A purposes, they are treated as paid by A Co. to B Co. during the life of the repo. Because Country A treats A Co. as having paid the amount of the dividend across to B Co., Country A grants a deduction for the amount of the dividend paid to and retained by B Co.

The discussion draft proposes to neutralize the tax benefit under the foregoing mismatches through the adoption of a linking rule that would seek to align the tax outcomes for the payor and the recipient under a financial instrument. The primary response would be to deny the payor a deduction for payments made under the hybrid financial instrument. In the event the payor is located in a jurisdiction that does not apply the primary rule, the payment would be included in the income of the recipient when computing tax in its country of residence. In addition, the dividends-received deduction that applies to a corporate recipient of a dividend would not apply to payments that are deductible for the payor. Payments under hybrid instruments would be included within this rule.

### **Hybrid Entity Payments**

These are transactions where differences in the characterization of the hybrid payor result in either (a) a deductible payment being disregarded in the country of residence of the recipient or (b) the allowance of a deduction in another jurisdiction so that the payment is deducted twice, each time offsetting income taxed separately in one, but not both, jurisdictions. The most common double deduction hybrid technique involves the use of a hybrid subsidiary that is treated as transparent under the laws of the investor's tax jurisdiction and opaque under the laws of the jurisdiction where it is established or operates. An opaque entity is treated as an entity, but is entitled to benefits under an income tax treaty. This hybrid treatment can result in the same item of expenditure incurred by the hybrid

being deductible under the laws of both the investor and subsidiary jurisdictions, as illustrated in the following diagram:

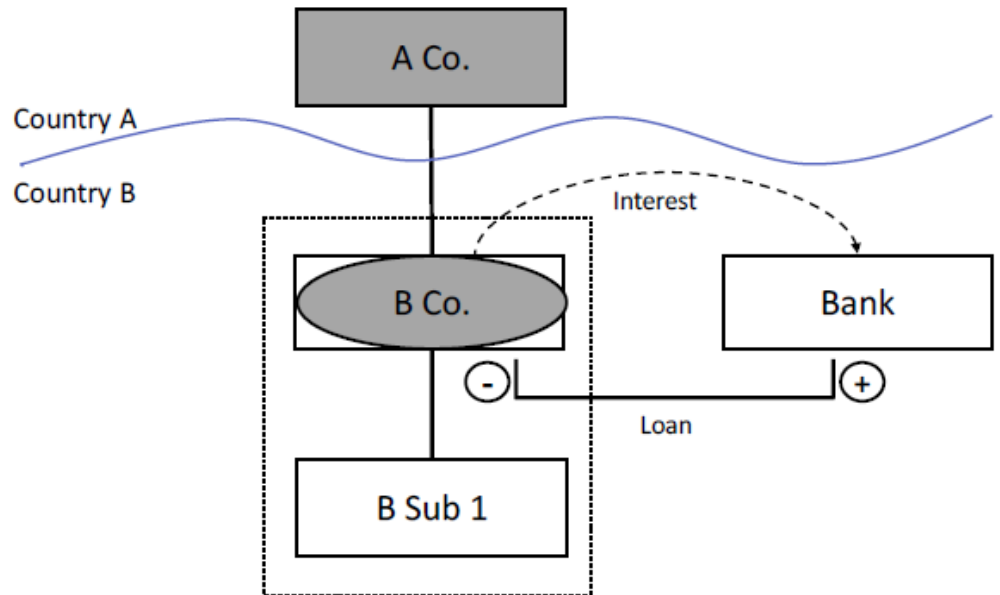

In this example, A Co. holds all the shares of a foreign subsidiary (B Co.). B Co. is a hybrid entity that is disregarded for Country A tax purposes. B Co. borrows from a bank and pays interest on the loan. B Co. derives no other income. Because B Co. is disregarded, A Co. is treated as the borrower under the loan for the purposes of Country A's tax laws. The arrangement therefore gives rise to an interest deduction under the laws of both Country B and Country A. B Co. is consolidated, for tax purposes, with its operating subsidiary B Sub 1, which allows it to surrender the tax benefit of the interest deduction to B Sub 1. The ability to "surrender" the tax benefit through the consolidation regime allows the two deductions for the interest expense to be set-off against separate income arising in Country A and Country B.

The same structure can be used without involving a hybrid entity, provided the subsidiary jurisdiction allows permanent establishments to consolidate for tax purposes with other resident companies. The diagram below illustrates this structure:

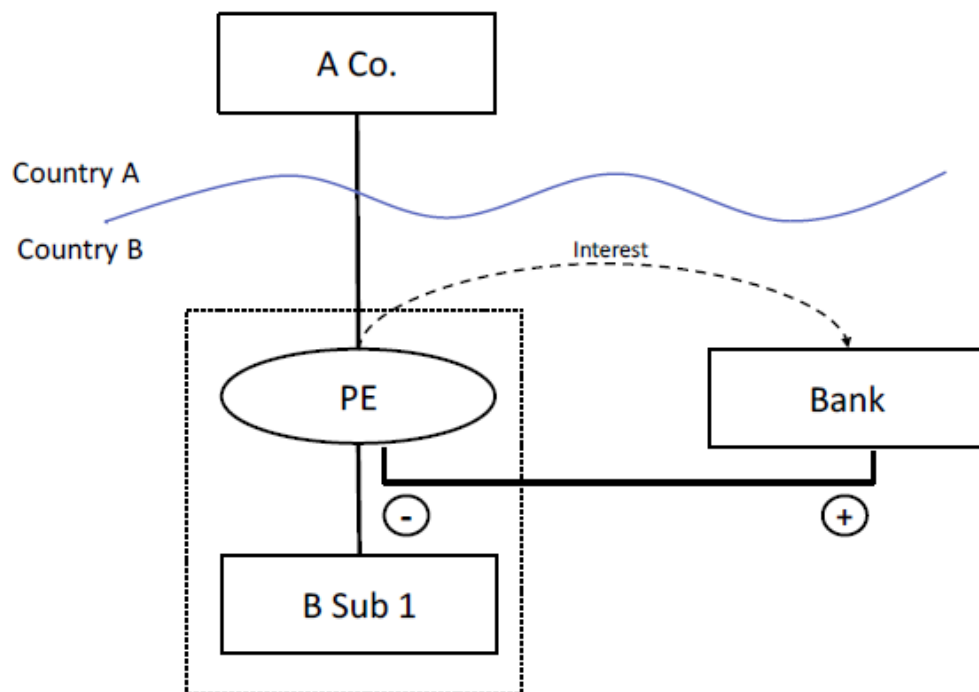

If the consolidation regime in Country B treats the permanent establishment (PE) as if it were a local entity and permits the permanent establishment to “surrender” the tax benefit of the deduction to B Sub 1, the result is the same as in the preceding illustration. The equivalent interest expense can be set-off against separate income arising in Country A and Country B.

The double deduction outcome raises base erosion issues only when interest expense deduction is eligible to be set-off against income that is not subject to tax in the other jurisdiction. This effect can be demonstrated by assuming, in the above example, that B Co. (or PE) derives no income. In such a case the interest expense that is deemed to arise in Country A might then be set-off against A Co.’s in-country income, thus reducing the amount of tax payable under Country A law. It can also be surrendered to B Sub 1, allowing it to be used against income taxable only in Country B.

According to the discussion draft, the double deduction opportunity gives rise to tax policy concerns, from the perspective of the investor jurisdiction, for the following reasons:

- The hybrid entity is usually structured so that it never generates a net profit; this ensures that there is never sufficient dual inclusion income to eliminate the mismatch generated by the duplicate deduction.
- In the event the hybrid entity does begin to generate surplus dual inclusion income, the investor can simply restructure its holdings in the hybrid entity to prevent the surplus income from being included under the laws of the investor jurisdiction.



- The loss surrender mechanism in the subsidiary jurisdiction can be used to make the mismatch in tax outcomes permanent. The surrendering of surplus deductions to non-hybrid entities means that the deduction will no longer be available to reduce any dual inclusion income that may be derived by the hybrid entity in the current or any subsequent period. Thus, any dual inclusion income derived by the hybrid in a subsequent period will be subject to tax under the laws of the subsidiary jurisdiction (Country B in the above examples) at the full rate, and such tax will be fully creditable under the laws of the investor jurisdiction (Country A in the above examples). The effect of the loss surrender under the consolidation regime therefore allows for each deduction to be set-off permanently against “other income,” permanently eroding the tax base of the investor jurisdiction.

A similar hybrid effect can be achieved by orchestrating a structure where the entity, while not hybrid, is a member of more than one tax consolidation group. This is illustrated in the following diagram:

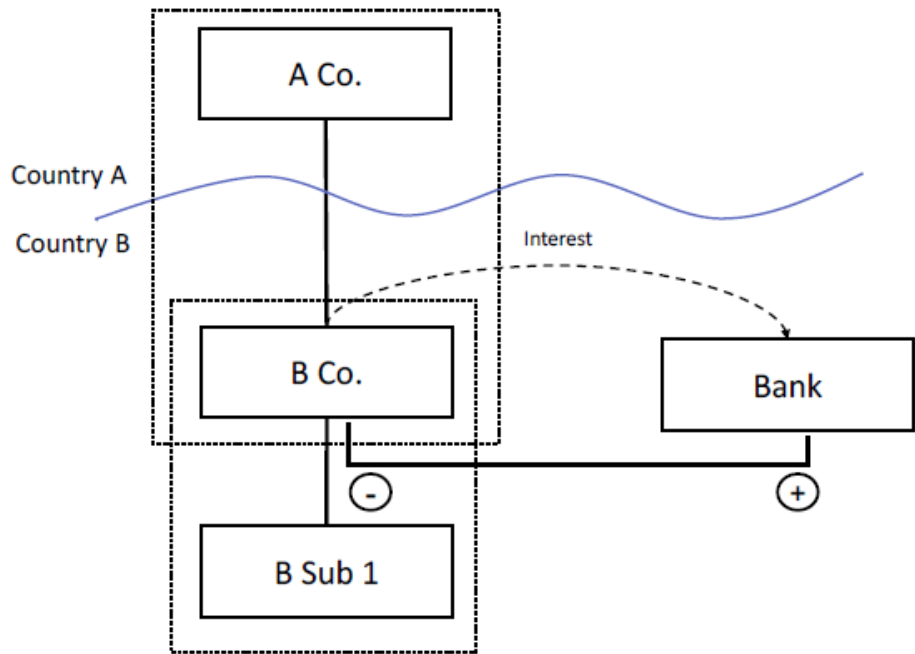

In the example, A Co. (a company incorporated and tax resident in Country A) holds all the shares in B Co. (a company incorporated in Country B but tax resident in both Country A and Country B). B Co. owns all the shares in B Sub 1 (a company incorporated and tax resident in Country B). B Co. is consolidated, for tax purposes, with both A Co. (under Country A law) and B Sub 1 (under B Country law). B Co. borrows from a bank and pays interest on the loan. B Co. derives no other income. Because B Co. is resident in both Country A and Country B, it is subject to tax on its worldwide income in both jurisdictions on a net basis and can surrender any net loss under the tax consolidation regimes of both countries to other resident companies. The ability to “surrender” the tax benefit through the consolidation regime in both countries allows the two deductions for the interest expense to be set-off against separate income arising in Country A and Country B.

The same basic hybrid technique can be used to engineer a deduction for a payment in the jurisdiction of residence of the payor without any income recognized in the jurisdiction of residence of the recipient. An example involves a payment made by a hybrid entity to its investor that is deductible under the laws of the payor's jurisdiction but disregarded under the laws of the investor's jurisdiction. This is illustrated in the following diagram:

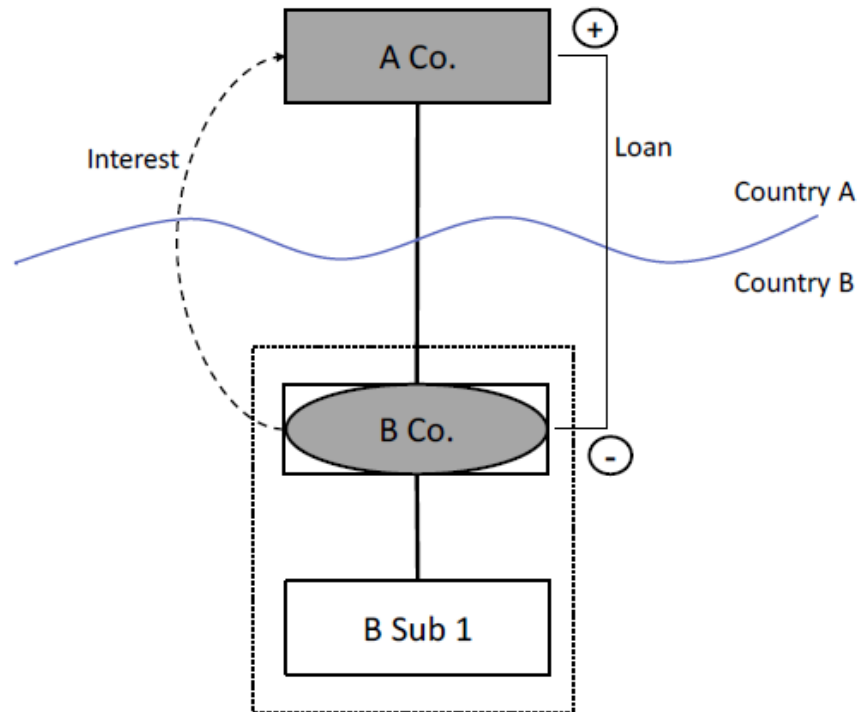

Tax benefits are derived because B Co. is treated as transparent under the laws of Country A. Because A Co. is the only shareholder in B Co., Country A simply disregards the separate existence of B Co. Disregarding B Co. means that the loan and the accompanying interest on the loan are ignored under the laws of Country A. In many cases, the funds lent from A Co. to B Co. are sourced from external borrowing by A Co. The arrangement therefore gives rise to an interest deduction under the laws of Country B but no corresponding inclusion under the laws of Country A. This deduction is then eligible to be offset against the income of B Sub 1 under the group consolidation regime. The ability to surrender the loss through the consolidation regime allows the deduction to be set-off against separate income arising under Country B law, producing a double deduction when funds are externally sourced by A Co.

The discussion draft proposes to address the hybrid payment issue through a linking rule that focuses only on whether the payment gives rise to a deduction in the subsidiary jurisdiction that could be offset against dual inclusion income. The rule would also have a primary/secondary structure so as to require application in one jurisdiction rather than both.

The double deduction rule isolates the hybrid element in the structure by identifying a deductible payment made by a hybrid in the subsidiary jurisdiction. This is referred to as the "hybrid payment." It also identifies the corresponding "duplicate deduction" generated in the jurisdiction of the investor. The primary recommendation is that the duplicate deduction cannot be claimed in the investor jurisdiction to the extent it exceeds the claimant's dual inclusion income, which is income that is brought into account for tax purposes under the laws of both jurisdictions. A secondary recommendation applies to the hybrid in the subsidiary jurisdiction to prevent the hybrid claiming the benefit of a hybrid payment against non-dual inclusion income if the primary rule does not apply. For both rules, excess deductions can be carried forward by a taxpayer and offset against future dual inclusion income.

In order to prevent stranded losses, the discussion draft recommends that excess duplicate deductions should be allowed to the extent that the taxpayer can establish, to the satisfaction of the tax administration, that the deduction cannot be set-off against the income of any person under the laws of the other jurisdiction.

The deduction/non-inclusion rule defines a disregarded payment as one that is made cross-border to a related party where the tax treatment of the payor results in the payment being disregarded under the laws of the jurisdiction in which the recipient is resident. The deduction that is generated by a disregarded hybrid payment cannot exceed the taxpayer's dual inclusion income. As a secondary rule, the recipient would be required to include the excess deductions in income.

### **Reverse Hybrid and Imported Mismatches**

Two arrangements are targeted by these rules. The first is an arrangement where differences in the characterization of the intermediary result in the payment being disregarded in both the intermediary jurisdiction and the investor's jurisdiction (reverse hybrids). The second is an arrangement where the intermediary is party to a separate hybrid mismatch arrangement, and the payment is set-off against a deduction arising under that arrangement (imported mismatches).

In the reverse hybrid arrangement, the hybrid is treated as opaque by its foreign owner and transparent under the jurisdiction where it is established. This is illustrated by the following diagram:

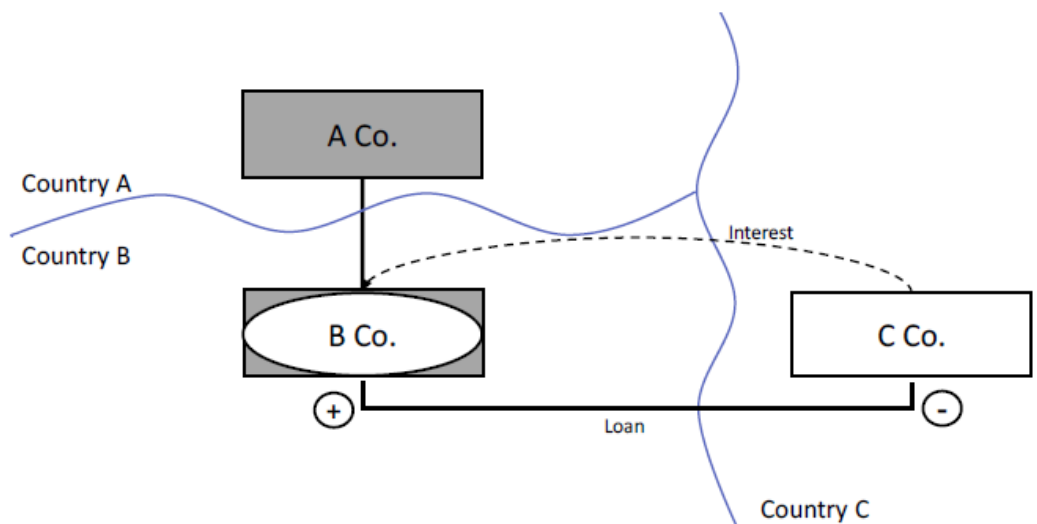

A Co. is a company resident in Country A, the investor jurisdiction. It owns all of the shares in B Co., a foreign subsidiary established under the laws of Country B, the intermediary jurisdiction. B Co. is treated as transparent for tax purposes under the laws of Country B but is regarded as a separate taxable entity under the laws of Country A. C Co., a company resident in Country C, the payor jurisdiction, borrows money from B Co. and makes interest payments under the loan. The payment is deductible under the laws of the payor jurisdiction, Country C, but is not included in income under the laws of either the investor or the intermediary jurisdiction because neither such jurisdiction treats the payment as income of a resident. Instead, each country treats the income as being derived by a resident of the other jurisdiction. This assumes that A Co. does not maintain a taxable presence in the intermediary jurisdiction. If it did (e.g., to enable B Co. to act as a dependent agent), Country B might impose tax.

The mechanics of reverse hybrid structures also make it difficult for any party to the arrangement to know the nature and extent of the mismatch unless the arrangement is implemented within the confines of a controlled group. Reverse hybrids mismatches can arise in the context of widely-held investment vehicles that admit offshore investors.

In the imported mismatch system, a hybrid instrument is used to reduce or eliminate the income in the intermediary jurisdiction. The intermediary company then lends funds raised with the hybrid instrument in return for a note from a borrower in a third country. The following diagram illustrates the fact pattern:

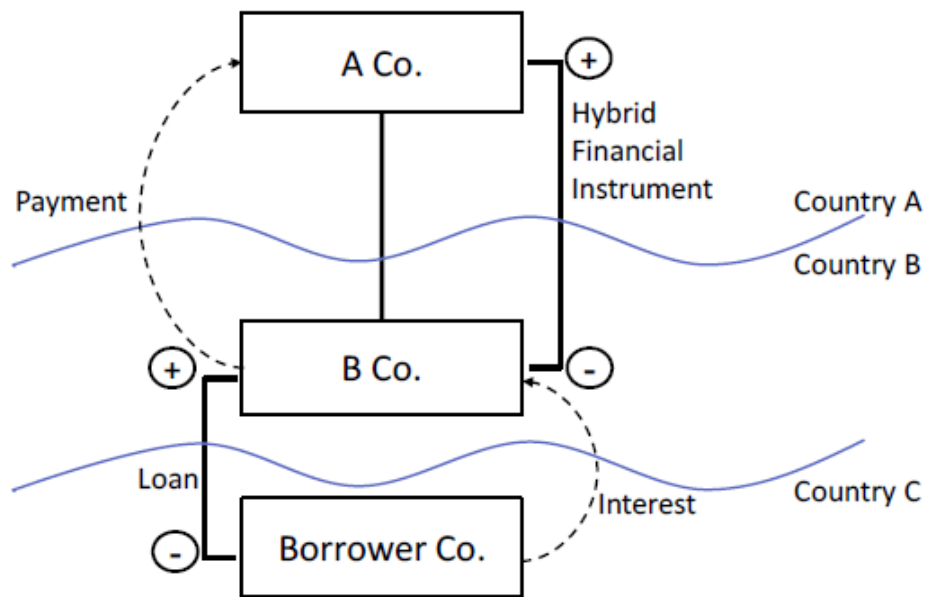

B Co. is a wholly-owned subsidiary of A Co. A Co. lends money to B Co. in return for the issuance of a hybrid financial instrument. The payments are structured to be exempt from tax under the laws of Country A, while being deductible under the laws of Country B. Borrower Co. borrows money from B Co. Interest payable under the loan is deductible under the laws Country C (the jurisdiction of residence of Borrower Co.) and is included in income by B Co. under Country B law. The result

of this structure is that interest is deductible in Country C, but ultimately is not deductible in Country A. Country B's tax revenue is unaffected as income is offset by deductions.

A similar result can be achieved through the use of a series of hybrid entities, as illustrated in the following diagram:

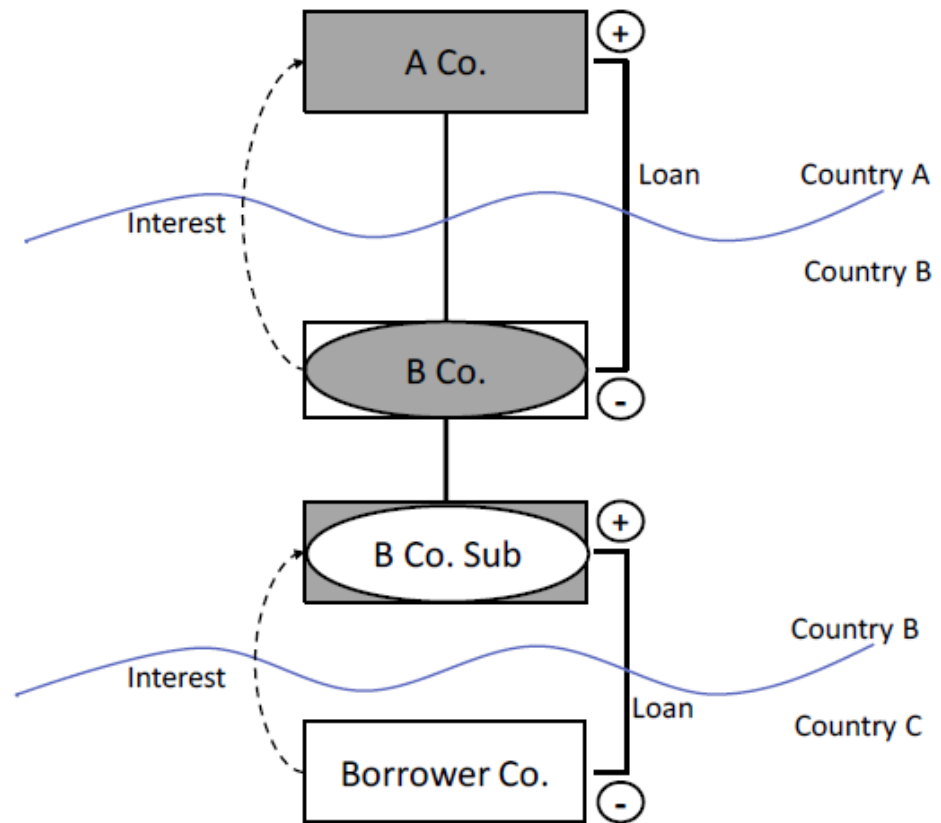

In the structure, A Co., a Country A resident, establishes a wholly-owned subsidiary B Co., a resident of Country B. B Co. is a hybrid that is treated as transparent under the laws of Country A. B Co. forms a wholly-owned subsidiary B Co. Sub. B Co. Sub is a “reverse hybrid” entity from the perspective of Country A. It is treated as transparent for tax purposes under the laws of Country B but as a separate taxable entity under the laws of Country A.

A Co. lends money to B Co. B Co. uses the money to acquire equity in B Co. Sub. B Co. Sub lends money to Borrower Co., an unrelated entity resident in Country C. Because Country A disregards the separate existence of B Co., it ignores the loan and the interest on the loan. This part of the structure therefore gives rise to an interest deduction under the laws of Country B but no corresponding inclusion under the laws of Country A. Interest payable under the loan between Borrower Co. and B Co. Sub is deductible under the laws of Country C and is included in income under Country B law. Country B treats B Co. Sub as a transparent entity

and will include its income in B Co.'s income. However, the income will be offset by the interest deduction under the loan arrangement between A Co. and B Co.

The net result of this structure is that Borrower Co. has a deduction, the income and expense of B Co. and B Co. Sub eliminate tax in Country B, and A Co. has no taxable income.

The discussion drafts propose the following rules to address the foregoing perceived abuses. In respect of imported mismatch arrangements other than reverse hybrids, comprehensive hybrid mismatch rules in the investor or the intermediary jurisdiction should be adopted that would be sufficient to prevent imported mismatches being structured through those jurisdictions. It proposes that all countries adopt the same set of hybrid mismatch rules. This approach ensures that the arrangement is neutralized in the jurisdiction where the hybrid technique is deployed, and there would be no resulting mismatch that could be exported into a third jurisdiction. A comprehensive solution where all countries establish the same set of hybrid mismatch rules will also generate compliance and administration efficiencies and certainty of outcomes for taxpayers.

To address reverse hybrid structures and provide measures designed to protect the payor jurisdiction from imported mismatches, the discussion draft makes two recommendations. The first is the adoption of rules that require income of, or payments to, a reverse hybrid to be included in income under the laws of the investor jurisdiction. It would be supported by the adoption of rules requiring income of, or payments to, a reverse hybrid to be included under the laws of the intermediary jurisdiction, if not included under the laws of the investor jurisdiction. The second recommendation is the adoption of rules that would allow the payor jurisdiction to deny the deduction for payments made to an offshore structure including an imported mismatch structure or reverse hybrid where the parties to the mismatch are members of the same controlled group or the payor has incurred the expense as part of an avoidance arrangement.

## TREATY ISSUES

To supplement the detailed discussion draft of proposed changes to domestic law, a discussion draft was also published regarding changes in the O.E.C.D. Model Tax Convention.

The discussion draft proposes to change the Article 4 (Resident) paragraph (3) of the O.E.C.D. Model Tax Convention to address some of the B.E.P.S. concerns related to dual-resident entities. It will provide a revised method of allocating tax residence by adopting a case-by-case method, instead of the current place of effective management. In essence, it will likely prevent any single rule or approach from being controlling in all circumstances. Certainty of result is given second position to prevention of abuse.

Paragraph 3 of Article 4 would be modified to read as follows:

*Where by reason of the provisions of paragraph 1 a person other than an individual is a resident of both Contracting States, the competent authorities of the Contracting States shall endeavour to determine by mutual agreement the Contracting State of which such*

*person shall be deemed to be a resident for the purposes of the Convention, having regard to its place of effective management, the place where it is incorporated or otherwise constituted and any other relevant factors. In the absence of such agreement, such person shall not be entitled to any relief or exemption from tax provided by this Convention except to the extent and in such manner as may be agreed upon by the competent authorities of the Contracting States. [Emphasis supplied.]*

The discussion draft acknowledges that the revision will not address all B.E.P.S. concerns related to dual-resident entities. Thus, an entity could be a resident of a given State under that State's domestic law while, at the same time, being a resident of another State under a tax treaty concluded by the first State. This would allow that entity to benefit from the advantages applicable to residents under domestic law – for example, being able to shift its foreign losses to another resident company under a group relief system – without being subject to reciprocal obligations regarding global taxation – it could claim treaty protection against taxation of its foreign profits. The draft suggests that countries adopt domestic legislation providing that an entity considered to be a resident of another State under a tax treaty will be deemed not to be a resident under domestic law.

The 1999 O.E.C.D. report on *The Application of the OECD Model Tax Convention to Partnerships* (the "Partnership Report") contains an extensive analysis of the application of treaty provisions to partnerships, including situations where there is a mismatch in the tax treatment of the partnership.<sup>3</sup> The discussion draft proposes to expand the scope of the Partnership Report to other transparent entities. Thus it proposes to modify Article 1 (Persons Covered) by inserting a new paragraph 2, providing as follows:

For the purposes of this Convention, income derived by or through an entity or arrangement that is treated as wholly or partly fiscally transparent under the tax law of either Contracting State shall be considered to be income of a resident of a Contracting State but only to the extent that the income is treated, for purposes of taxation by that State, as the income of a resident of that State.

The new text would be supported by the adoption of additional commentary. An example in the proposed commentary explains how the provision would be applied:

State A and State B have concluded a treaty identical to the Model Tax Convention. State A considers that an entity established in State B is a company and taxes that entity on interest that it receives from a debtor resident in State A. Under the domestic law of State B, however, the entity is treated as a partnership and the two members in that entity, who share equally all its income, are each taxed on half of the interest. One of the members is a resident of State B and the other one is a resident of a country with which

---

<sup>3</sup> OECD (1999), *The Application of the OECD Model Tax Convention to Partnerships*, Issues in International Taxation, No. 6, OECD Publishing. doi: [10.1787/9789264173316-en](https://doi.org/10.1787/9789264173316-en).

States A and B do not have a treaty. The paragraph provides that in such case, half of the interest shall be considered, for the purposes of Article 11, to be income of a resident of State B.

The proposed commentary explains that the reference to “income derived by or through an entity or arrangement” is to be given a broad meaning. It is intended to cover any income that is earned by or through an entity or arrangement, regardless of (a) the view taken by each Contracting State as to who derives that income for domestic tax purposes and (b) whether or not that entity or arrangement has legal personality or constitutes a person. It would cover income of any partnership or trust that one or both of the Contracting States treats as wholly or partly fiscally transparent. It does not matter where the entity or arrangement is established. The paragraph applies to an entity established in a third State to the extent that, under the domestic tax law of one of the Contracting States, the entity is treated as wholly or partly fiscally transparent and income of that entity is attributed to a resident of that State.

In the case of an entity or arrangement which is treated as partly fiscally transparent under the domestic law of one of the Contracting States, only part of the income of the entity or arrangement might be taxed at the level of the persons who have an interest in that entity or arrangement, as described in the preceding paragraph, whilst the rest would remain taxable at the level of the entity or arrangement. This provision is intended to apply to (a) trusts that are fiscally transparent when distributions are made from current income and (b) a separate taxpayer for accumulated income. To the extent that the trust qualifies as a resident of a Contracting State, the provision will ensure that the benefits of the treaty will also apply to the share of the income that is taxed at the trust level by the jurisdiction of residence.

The proposed paragraph does not prejudge whether the transparent entity or its members are the beneficial owners of the income. Thus, for example, a fiscally transparent partnership that receives dividends as an agent or nominee for a person who is not a partner does not preclude the State of source from considering that neither the partnership nor the partners are the beneficial owners of the dividend. The fact that the dividend may be considered as income of a resident of a Contracting State under the domestic law of that State is not controlling on the tax treatment of the source State.

## CONCLUSION

The discussion draft on hybrid entities is an ambitious attempt to limit tax planning that has existed for decades. Whether it can be implemented universally remains an open question.



# THE O.E.C.D.'S APPROACH TO B.E.P.S. CONCERNS RAISED BY THE DIGITAL ECONOMY

## Authors

Stanley C. Ruchelman  
and Alev Fanny Karaman

## Tags

O.E.C.D.  
B.E.P.S.  
Digital Economy

On March 24, 2014, ten days after the O.E.C.D. released its public discussion draft on prevention of treaty abuse,<sup>4</sup> a second public discussion draft was released, addressing the tax challenges of the digital economy (the “Discussion Draft”).<sup>5</sup>

The Discussion Draft emphasizes the concept that the digital economy should not be ring-fenced and separated from the rest of the economy, given its relationship to the latter. It provides a detailed introduction to the digital economy, including its history, components, operations, and different actors. Surprisingly, it does not propose any groundbreaking approaches to addressing the base erosion and profit shifting (“B.E.P.S.”) challenges encountered in the digital economy. It simply reflects an approach that is consistent with the fight against B.E.P.S. – seeking to determine where economic activity takes place in the digital economy in order to best achieve taxation in a non-abusive fashion.

The Discussion Draft singles out six factors that characterize the digital economy in light of B.E.P.S. concerns:

1. Mobility of all facets of the digital economy, including the intangibles used, the users themselves, and the business functions carried on by various players in the business model;
2. Reliance on data;
3. Network effects;
4. Use of multi-sided business models;
5. Tendency towards monopoly or oligopoly; and
6. Volatility.

---

<sup>4</sup> See [Client Alert March 18, 2014 Re: O.E.C.D. Public Discussion Draft on Preventing Treaty Abuse](#).

<sup>5</sup> See [Public Discussion Draft BEPS Action 1: Address the Tax Challenges of the Digital Economy](#).

*“The Discussion Draft addresses traditional B.E.P.S. concerns relating to direct and indirect taxation.”*

The Discussion Draft addresses traditional B.E.P.S. concerns relating to direct and indirect taxation. These include the avoidance of a taxable presence in the market place, the avoidance of withholding taxes through treaty-shopping, the minimization of tax in intermediate countries, the minimization of tax in the ultimate parent's home jurisdiction, and cross-border acquisitions by V.A.T. exempt purchasers. The Discussion Draft reiterates the O.E.C.D.'s stated goal in the B.E.P.S. project – that is, to ensure that taxation takes place at least once, preferably at the location of economic activities. This is particularly difficult to determine with respect to the digital economy, since the different actors, components, and users are generally spread over multiple jurisdictions.

With that in mind, the Discussion Draft proposes, *inter alia*, the following approaches to achieve appropriate taxation:

- Revisiting the Treaty definition of permanent establishment (“P.E.”) with a focus on the various exemptions for specific activities: These exemptions were drafted so as to avoid preparatory or auxiliary activities from giving rise to taxation. However, when applied to the digital economy, these preparatory or auxiliary activities may well constitute a core element of the given digital business.
- Creation of a two-step nexus test based on an entity's “significant digital presence” to evaluate whether P.E. exists: A preliminary set of factors would determine whether a given activity is fully dematerialized – that is, in broad terms, no physical presence exists in a country and no physical object is furnished to the customer. Once this determination is made, a second set of factors would establish whether an enterprise engaged in a fully dematerialized activity has a significant digital presence, in which case specific methods have been followed to reach a class of users or consumers in a particular country. As an alternative to this two-step test, the Discussion Draft proposes the use of personal data to reach a conclusion as to the presence of a P.E.
- Referring to the work of the Business Profits TAG, three alternative approaches to P.E. thresholds: (i) “virtual fixed place of business,” (ii) “virtual agency PE,” and (iii) “on-site business presence PE.”
- Creation of a withholding tax on digital cross-border transactions: This would be achieved by requiring the financial institution involved in online payment to withhold the required tax.
- With regard to V.A.T., a review of the exemption for low-valued goods: The Discussion Draft highlights the increased flow of cross-border acquisitions of low valued goods generated by the digital economy and correlated decrease in V.A.T. revenue.
- With regard to Business-to Consumer (“B2C”) transactions in the V.A.T. field, the most viable option is described as one under which the foreign supplier collects the V.A.T. and remits it to the jurisdiction of consumption: This should be coupled with simplified registration regimes and thresholds, as well as with an international cooperation mechanism between jurisdictions.

Another challenge addressed by the Discussion Draft involves the methods for attributing value to the collection of digital data. This refers to the practice whereby sophisticated tracking techniques allows digital merchants to identify items of interest for a specific group of consumers (such as French teenage girls living in Paris who respond to clothing advertisements) and the data is then sold to merchants and used to target specific items to that category of consumer. The Discussion Draft also raises questions concerning the character of certain income flows related to the digital economy, such as payments for cloud computing. Do they constitute payments for services, royalty payments or business profits?

The Discussion Draft mostly refers to other actions of the 2013 B.E.P.S. Action Plan to effectively address the B.E.P.S. concerns raised by the digital economy. It refers specifically to Action 2 (Neutralize the Effects of Hybrid Mismatch Arrangements), Action 4 (Limit Base Erosion via Interest Deductions and Other Financial Payments), Action 5 (Counter Harmful Tax Practices More Effectively), Action 6 (Prevent Treaty Abuse), Action 7 (Prevent the Artificial Avoidance of PE Status), and Actions 8-10 (Assure that transfer pricing outcomes are in line with value creation). Regarding consumption taxes, the Discussion Draft refers to Guidelines 2 and 4 of the O.E.C.D.'s "Guidelines on place of taxation for B2B supplies of services and intangibles." In addition, the Discussion Draft examines the importance of C.F.C. legislation and takes the position that C.F.C. regimes should address the taxation of income generally earned in the digital economy.

Comments on the Discussion Draft could be submitted electronically until April 14, and submitters wishing to speak in support of their comments were required indicate their intention to do so by April 7.



# WHAT MUST FOREIGN TRUSTS AND FAMILY CORPORATIONS DO ABOUT F.A.T.C.A.?

## Authors

Stanley C. Ruchelman  
and Philip R. Hirschfeld

## Tags

F.A.T.C.A.  
Trust  
Holding Company  
N.F.F.E.  
F.F.I.

After years of preparation and trepidation, the Foreign Account Tax Compliance Act (“F.A.T.C.A.”) will soon become effective. While F.A.T.C.A. was initially targeted to major commercial and investment banks aiding U.S. persons in avoiding paying tax on their income, F.A.T.C.A.’s effective scope is far broader, covering any foreign trust or family corporation. Starting on July 1, 2014, F.A.T.C.A. can impose a new 30% U.S. withholding tax on payments of interest, dividends and other amounts from the U.S. to *any* foreign person unless that person complies with F.A.T.C.A. regulations. If the foreign person is a foreign financial institution (“F.F.I.”), compliance is onerous. However, with the recent revisions to the regulations and careful planning, the foreign trust or family corporation may be considered a non-financial foreign entity (“N.F.F.E.”) and thus subject to far less burdensome requirements.

F.A.T.C.A. divides the world of non-U.S. investors into two categories: F.F.I.’s and N.F.F.E.’s. The crucial factor for any foreign person is to first determine its classification. As F.F.I. status results in a much greater burden for an entity and the deadlines for actions are fast approaching, obtaining N.F.F.E. status holds numerous advantages. For a typical foreign trust or family corporation that holds investments for its beneficiaries or shareholders, this determination had been clouded in uncertainty, until the I.R.S.’s recent issuance of temporary F.A.T.C.A. regulations.

Under F.A.T.C.A. regulations, a foreign trust or family corporation that derives its income from investments will be categorized as an F.F.I. if (1) the trust or corporation is managed by a business entity and not an individual and (2) that manager has investment discretion concerning what the trust or corporation buys or sells. For example, if the trust retains a large commercial bank or investment bank as its investment manager and that investment manager has discretion on securities to buy or sell, the trust is treated as an F.F.I. By contrast, if the trust retains an investment manager who is a sophisticated individual working on his or her own, or a family member, the trust would not be an F.F.I. In that case, the trust would be a passive N.F.F.E. that is subject to far less burdensome requirements under F.A.T.C.A.

If the trust or family corporation is treated as an F.F.I., it will be required to register on the F.A.T.C.A. electronic portal to become a participating F.F.I. (“P.F.F.I.”). A P.F.F.I. is not subject to F.A.T.C.A. withholding. Among the many burdens imposed on the P.F.F.I. is the requirement to search its records or obtain documentation to see if it has a U.S. grantor, a U.S. beneficiary, a U.S. shareholder, or a U.S. controlled foreign entity. The P.F.F.I. must disclose the U.S. person’s identity and certain related information to the I.R.S. Registration to

become a P.F.F.I. is subject to a tight deadline. The I.R.S. has stated that, unless an F.F.I. registers by April 25, it cannot be assured that the F.F.I. will receive a Global Intermediary Identification Number (“G.I.I.N.”) in time to prevent F.A.T.C.A. withholding.

However, help may be available to lessen some of the burdens on the trust or corporation and to provide more time to act. The U.S. has signed 24 Inter-Governmental Agreements relating to F.A.T.C.A. (“I.G.A.’s”) and the list is growing. For those countries that have signed a Model 1 I.G.A. (such as the U.K., Canada, the Cayman Islands, and Bermuda), the April 25 deadline is extended by six months. Additionally, the entity is obligated to report the names of the U.S. investors to the local country, rather than the I.R.S. However, Model 1 I.G.A. status does not completely eliminate the need to take action. Rather, I.G.A. status gives the F.F.I. more time by delaying registration or F.A.T.C.A. withholding until January 1, 2015.

If the trust or family corporation is treated as a passive N.F.F.E. rather than an F.F.I., it need not obtain a G.I.I.N. and is not subject to the same level of due diligence that is imposed upon an F.F.I. The foremost compliance burden placed on a N.F.F.E. is the requirement to disclose the names of certain U.S. shareholders and beneficiaries. U.S. shareholders owning more than 10% of the company, beneficiaries having a greater than 10% interest in the trust, and possibly the name of a U.S. grantor will need to be disclosed on I.R.S. Form W-8BEN-E. Form W-8BEN-E will be given by the trust or corporation to the U.S. withholding agent paying the interest, dividends, sales proceeds, redemption proceeds, and other items of U.S. source passive income. The U.S. withholding agent will alert the I.R.S. of the identity of these U.S. persons on Form 8966.

A passive N.F.F.E. that must disclose the identity of a U.S. person is given a new option in the recently finalized regulations. A passive N.F.F.E. can register with the I.R.S. to become a Direct Reporting N.F.F.E. This will allow greater confidentiality for the investors in the N.F.F.E. because the names of those U.S. persons will not be furnished to the withholding agent. The N.F.F.E. will provide the withholding agent with a G.I.I.N. that indicates the direct reporting N.F.F.E. status and provide the names of the U.S. investors directly to the I.R.S. on Form 8966. This option can simplify the reporting burdens all involved parties and also preserve the secrecy of the U.S. persons, except with regard to the I.R.S.

Foreign trusts and family corporations need to begin to consider how to deal with F.A.T.C.A. The initial impact of F.A.T.C.A. may not be felt, due to special rules that treat certain pre-July 1, 2014 instruments as not subject to F.A.T.C.A. withholding, but eventually F.A.C.T.A. will catch up to everyone.

*“A passive N.F.F.E. can register with the I.R.S. to become a Direct Reporting N.F.F.E. This will allow greater confidentiality for the investors in the N.F.F.E. because the names of those U.S. persons will not be furnished to the withholding agent.”*



# TRANSFER PRICING – BANKRUPTCY COURT PREVENTS I.R.S. FROM PURSUING UNSUPPORTED TRANSFER PRICING CLAIMS; *IN RE: DeCoro USA, Limited, Debtor* (2014 U.S.T.C. PAR 50,227)

**Author**  
Robert G. Rinninsland

**Tags**  
Transfer Pricing

## INTRODUCTION

A recent decision by the U.S. Bankruptcy Court, Middle District North Carolina (the “Court”) provides interesting guidance on the practical application of U.S. transfer pricing rules. While one would not normally expect significant transfer pricing insight from a bankruptcy court, an I.R.S. claim for tax due caused the Court to apply U.S. tax transfer pricing rules in a surprisingly clear, concise and practical manner in order to determine the validity of the claim. In holding the claim invalid, the Court provided valuable guidance to taxpayers and the I.R.S. alike, finding that assertions of underpayment of tax in connection with the pricing of a controlled transaction must be based on the facts presented, rather than those imagined by the I.R.S.

## BACKGROUND FACTS

The DeCoro Group was founded in 1997 by an Italian businessman whose goal was to produce high quality Italian leather furniture at affordable prices on a worldwide basis. In order to accomplish this, a Chinese manufacturing plant was purchased then expanded. Business management of the DeCoro Group was carried out by DeCoro Limited (“DCL”), a Hong Kong company. Strategic customer relationships with furniture retailers around the world were developed and maintained by DCL. Through a Chinese manufacturing facility, DCL was engaged in the manufacture and sale of high end leather furniture.

DeCoro USA (“DUSA”) is a North Carolina company. It is a wholly-owned subsidiary of DCL. Furniture sales to customers in the U.S. – typically retail chains – were procured by DUSA, through its employees or independent sales representatives it engaged. DUSA acted under a distribution agreement with DCL. Under the agreement, the purported arrangement was one in which the furniture that it sold to customers in the U.S. was “purchased” from DCL. In doing so, DUSA “paid” DCL essentially the same amount that it charged the customers as the sales price of the furniture. It was entitled to a “commission” equal to cost plus 10%.

*“...the I.R.S. transfer pricing adjustment may not be overturned unless it is arbitrary, capricious or unreasonable. On the facts before it that were related to the functions and risks taken on by DUSA, the Court held that the I.R.S. assertion was arbitrary and capricious...”*

During 2008 or early 2009, the I.R.S. began an examination regarding the U.S. tax liability of DCL and DUSA. The primary question during this examination was which company should pay the income tax due from furniture sales to customers located in the U.S. and depended upon which company should be regarded as the seller. If DUSA were a dependent agent of DCL, then the sales would be treated as having been made by DCL and it would be taxed as a foreign corporation making sales in the U.S. This was the primary position of the I.R.S. during the pre-petition audit. Conversely, if DUSA were an independent distributor, then the sales would be treated as having been made by DUSA and it would be liable for any income taxes due as a result of the domestic sales. This was the position of DUSA during the audit.

In February 2009, the I.R.S. issued an audit letter asserting that income taxes would be assessed against DCL based upon the furniture sales to customers in the U.S. However, prior to any assessment being made by the I.R.S., DCL filed an insolvency proceeding in Hong Kong and DUSA filed for bankruptcy relief in U.S. Bankruptcy Court. No further action was taken by the I.R.S. prior to filing its proof of claim in the bankruptcy proceeding.

The I.R.S. filed its proof of claim in June of 2009. The claim, as subsequently amended, asserted a tax deficiency of approximately \$11.2 million including \$1.8 million of pre-petition interest. The I.R.S. asserted that DUSA failed to report proper income, as required by I.R.C. §482, in its capacity as an independent distributor of DCL's products in the U.S. Under relevant provisions of U.S. tax law, the claim consisted of: (i) a primary adjustment that increased DUSA's operating margin for the audit period, thereby materially increasing its tax; and (ii) a secondary adjustment that reconciled DUSA's cash position to the I.R.S. assertion of greater income – a corporation that is taxed as if it received a greater amount of income must have paid a dividend to bring down its cash balance to the actual amount on hand. This resulted in an assessment of dividend withholding tax of 30% of the amount of deemed dividends. In a footnote to its proof of claim, the I.R.S. offered to reduce the secondary adjustment if DCL conceded it was taxable on the profits from sales in the U.S.

As is readily apparent, the basis for the proof of claim was inconsistent with the I.R.S. position in the examination, which resulted in a notice of proposed adjustment. However, given the two bankruptcy filings and the fact that DCL's situation involved Hong Kong liquidators, the I.R.S. chose what it perceived to be the path of least resistance for its claim; it chose to assert that DUSA was indeed a distributor and not a sales agent or facilitator. This approach forced DUSA to assert that DCL made the sales and that the cost plus arrangement was appropriate under principals of Code §482 for a facilitator of sales. The tactic also forced the Court to consider the merits of the I.R.S. and taxpayer flip-flop of positions ordinarily taken in this type of fact pattern.

## **BANKRUPTCY COURT HOLDING & RATIONALE**

The Court disallowed the I.R.S. claim as filed, finding that DUSA was a facilitator of sales, not a distributor that purchased and sold inventory. In this regard, the Court noted that DUSA had taxable income whether it was a full-fledged, independent distributor of products purchased from DCL, as contended by the I.R.S., or was

merely a facilitator or commissionaire as contended by DUSA. The issue was to determine the profit level that was appropriate to the functions actually performed.

The Court began by confirming the key components of a transfer pricing analysis as set forth in the tax regulations under Code §482 and the Internal Revenue Manual. These components are: (i) the application of the best method of transfer pricing, (ii) the specific factors in determining comparability, and (iii) the determination of the arms-length range. The Court had the benefit of expert testimony given for the I.R.S. and DUSA.

With advice of the experts, the Court examined the four step process required to select the best method of transfer pricing. These are: (i) the functional and risk analysis, (ii) the search for comparables, (iii) the determination of the arms-length range, and (iv) the determination of whether the transaction falls within the range that is determined. It was clear to the Court that the analysis of functions and risks was key to a proper transfer pricing analysis. DUSA's expert explained that the analysis determines the "value creation" of the tested party based on the relative assets employed and risks borne in the controlled transaction. Once value creation by the tested party is determined, the results of comparable companies and transactions can be identified and the most reliable arms-length result can be reached by applying the best method.

The Comparative Profits Method ("CPM") was determined to be the best method of transfer pricing by both the taxpayer and the I.R.S. CPM evaluates transfer pricing by reference to objective measures of profitability, referred to as profit level indicators ("PLI's"), generally expressed in percentage terms. DUSA's expert characterized DUSA as a service provider rather than a distributor. His report stated that:

[T]he profits of entities that have as a main focus maximizing sales turnover should generally be compared under the CPM using a PLI with sales in the basis...entities that are primarily service providers [such as DUSA] incur operating expenses as a result of their value adding activities and so generally should be compared under the CPM using operating expenses in the base of the PLI.

In its paper work, the I.R.S. chose operating margin as the most reliable profit level indicator. Operating margin is a measurement of the proportion of a company's revenue that is left over after paying for variable costs of production such as wages and raw material. It is determined by dividing the operating income before interest and taxes by net sales. However, at trial, both the I.R.S. and DUSA applied the "Berry Ratio" as the proper PLI. The Berry Ratio is the ratio of a company's gross profits to its operating expenses. In other words, the selected denominator of the Berry Ratio is operating expenses. Thus a comparable which had a profit of 100 and operating expenses of 90 would have a Berry Ratio of 1.11 (calculated as profits over operating expenses or 100/90).

The key is to identify the appropriate group of comparable companies so that the Berry Ratio can be applied properly. Here DUSA used one set of comparables – service providers – and the I.R.S. used a different set – distributors. It then applied the typical presumption of correctness in transfer pricing cases, viz., the I.R.S. transfer pricing adjustment may not be overturned unless it is arbitrary, capricious or unreasonable. On the facts before it that were related to the functions and risks taken on by DUSA, the Court held that the I.R.S. assertion was arbitrary and

*"The Court disallowed the I.R.S. claim as filed, finding that DUSA was a facilitator of sales, not a distributor that purchased and sold inventory."*



capricious because it ignored the activity of the tested party and was based primarily on the terms of an agreement that was less than pristine.

According to the Court, the functions and risks assumed by DUSA were consistent with the limited role of a service provider that facilitated sales. It was nothing like the functions and risks of the value add distributors that formed the basis of the I.R.S. adjustment. Consequently, benchmarking to service type companies such as freight forwarders was appropriate. In comparison, the I.R.S. benchmarked to full-fledged distributors having functional responsibilities and risks for inventory, logistics, credit, and product warranties. DUSA never took title to inventory, had minimal customer contacts, never concluded contracts, and never set sales prices. The Court pointed out that one of the cardinal rules, embodied in the I.R.S. regulations under Code §482, is that intercompany agreements which do not represent the substance of the transactions are not controlling for transfer pricing purposes. In this regard, the Court took judicial notice of phrases used by the I.R.S. in its notice of proposed adjustment, such as “commissionaire” and “representative of the principal” to describe DUSA as a dependent agent of DCL. The I.R.S. could not characterize DUSA in that limited fashion and then change its characterization to a full-fledged distributor without point to specific facts other than the agreement.

## CONCLUSIONS

The case illustrates several key points to be considered in the development and implementation of proper transfer pricing, from both the taxpayer and I.R.S. perspective. Many of these points can be taken from language in the case itself.

1. Align transfer pricing strategy for tax purposes with the enterprise's business model: The Court accepted the description of DUSA's functions and risks given by U.S. senior management and was convinced that DUSA “had no autonomy or independence and effectively no discretion regarding matters relating to furniture sales.” This testimony was given without objection and was key to the functional and risk analysis which was the basis of DUSA's transfer pricing position.
2. Monitor written intercompany agreements and amend them if necessary to reflect changes in the business: There were inconsistencies between the terms and conditions of the distribution agreement and the way DUSA interfaced with DCL. The distribution agreement provided the I.R.S. with an opportunity to argue that DUSA was operating as a full-fledged distributor. While this was ultimately disproved, a full hearing before the Court was required before the matter could be sorted out.
3. The quality of a transfer pricing analysis depends on the quality of the comparables: The comparables selected by the I.R.S. did not match the functions and risks of DUSA. This was fatal to analysis supporting the I.R.S. position.
4. Know the comparables: Related to point 3, one should know why a given comparable company has been selected and how that company's functions and risk relate to the tested party's functions and risks. The I.R.S. analysis of comparables was based on brief excerpts of 10-K reports and did not

exhibit sufficient knowledge of how the comparable companies conducted their business.

5. Substance trumps writing: Substance eventually should control regardless of the content of written agreements, policies or procedures that are simply not followed.
6. Profit Level Indicators are important: The PLI's are key to proper application of the CPM. They focus the CPM analysis on the specific component of the value chain that reflects the economics of the controlled transaction. This enables a separate analysis of transfer pricing without undue consideration of business conditions that affect overall profitability of the tested party but which are unrelated to transfer pricing itself.
7. Hold the I.R.S. accountable: In sum, the I.R.S. deserved what it got. It took inconsistent positions in its notice of proposed adjustment and the principal arguments for its bankruptcy claim. The I.R.S. allowed its expert to conduct a faulty transfer pricing analysis and based the argument for its claim on that faulty analysis. In its own way, the I.R.S. departed from its own "substance over form" rules by limiting its factual submission to the contents of the distribution agreement while ignoring input provided by business management, the independent bankruptcy liquidator, and empirical business data (e.g., invoices, customs, customer contracts, warehousing, capital expenditures, and general ledgers).

Finally, there is a troubling aspect to this case from an I.R.S. tax administration standpoint. The case came to trial in September 2013. Both parties were permitted to file additional briefs. The additional briefs were also reviewed by the Court and considered along with all other arguments, testimony, evidence, etc. in its March 18, 2014 decision. Simultaneously with these developments, the I.R.S. had been rolling out its Transfer Pricing Operations ("T.P.O.") group and its new, more robust transfer pricing audit strategy, as detailed in the February 2014 Transfer Pricing Audit Roadmap and the quality examination process ("Q.E.P."). The process entails a "working hypothesis" and upfront identification and prioritization of transfer pricing issues. The accuracy of the notice of proposed adjustment, and the continued development of facts relevant to the remaining audit process and beyond have been noted as key components of these initiatives. If the I.R.S. performance in the this case is any indication of the way these initiatives are being carried out in practice, taxpayers fears regarding I.R.S. behavior may appear justified.

*"In sum, the I.R.S. deserved what it got. It took inconsistent positions in its notice of proposed adjustment and the principal arguments for its bankruptcy claim."*



# TAX 101 – INTRODUCTORY LESSONS: FINANCING A U.S. SUBSIDIARY – DEBT VS. EQUITY

## Authors

Galia Antebi  
and Nina Krauthamer

## Tags

Debt  
Equity

## INTRODUCTION

When a foreign business contemplates operating in the U.S. through a U.S. subsidiary corporation, it must take into account the options available for funding the subsidiary. As a practical matter, a foreign-owned subsidiary may encounter difficulty in obtaining external financing on its own, and thus, internal financing is often considered. It is a common practice for a foreign parent corporation to fund its subsidiary through a combination of equity and debt.

Using loans in the mixture of the capital structure is often advisable from a tax point of view. Subject to the general limitations under the Internal Revenue Code (the “Code”),<sup>6</sup> financing the operations with debt will result in a U.S. interest expense deduction, often with a meaningful reduction of the overall tax rate applicable to the operation. (It should be noted that the U.S. has one of the highest corporate tax rates in the world.) Additionally, repayment of invested capital (in the form of debt principal) will be free of U.S. withholding tax if the investment qualifies as a debt instrument for U.S. tax purposes. If the lender is a resident of a treaty jurisdiction and eligible for treaty benefits, the interest payments will be subject to a reduced rate of taxation – or a complete elimination of taxation<sup>7</sup> – under the treaty.<sup>8</sup> Another reason multinational entities use debt to finance their subsidiaries is the possibility for tax arbitrage resulting from the differing treatment in various countries of debt and equity.

---

<sup>6</sup> E.g., the “earning stripping” rules of Code §163(j) and the “matching rule” of Code §267(a).

<sup>7</sup> E.g., under Article 11 of the treaty between the U.S. and the Russian Federation no U.S. tax will be imposed on U.S. source interest paid to a Russian resident eligible for treaty benefits.

<sup>8</sup> Interest payments qualifying for the “portfolio interest exemption” are not subject to U.S. withholding tax. To qualify, the indebtedness instrument must be in registered form, the foreign lender must not own 10% or more of the voting power of the borrower (after application of constructive ownership and attribution rules), and the interest must not be contingent on the business performance of the borrower or a related party. Intercompany indebtedness generally does not qualify.

In certain circumstances debt treatment may be re-characterized by the I.R.S. as equity. As a general proposition, the classic criteria for debt requires that a loan be repaid on maturity and bear interest payable at certain events during the term of the loan, no later than on maturity. For that reason, financing a U.S. subsidiary with an interest-free debt is problematic, resulting in a risk that the investment be re-characterized as equity.

If the I.R.S. re-characterizes the loan as equity, any interest deduction taken will be disallowed and any interest payment made to the creditor will be treated as an equity distribution, which will be considered as a dividend to the extent of the earnings and profits of the borrower. Additionally, when an interest deduction is disallowed, the subsidiary could be found to have a higher tax obligation and could be subject to interest and penalties with respect to the possible underpayment of taxes. Further, the subsidiary would be required to withhold tax on payments treated as distributions (at a rate of 30% or less if a treaty is applicable), and because it has not done so in a timely manner, this could result in additional penalties.

## DEBT OR EQUITY?

Code §385 was enacted in 1969, authorizing the Treasury (I.R.S.) to issue regulations to determine whether an instrument is to be treated as debt or equity. The factors to be considered are: (i) whether there is a written unconditional promise to pay on demand or on a specified date a certain sum of money in return for an adequate consideration in money or money's worth, and to pay a fixed rate of interest; (ii) whether there is subordination to or preference over any indebtedness of the corporation; (iii) the ratio of debt to equity of the corporation; (iv) whether there is convertibility into the stock of the corporation; and (v) the relationship between holdings of stock in the corporation and holdings of the interest in question. Following the authorization, Treasury regulations were proposed, finalized, re-proposed and finally withdrawn. One commentator described the regulatory project as a “fiasco.”<sup>9</sup>

Over the years, however, the U.S. courts established several factors to determine when capital investment will be treated as debt or equity. The treatment of debt or equity in a non-arm's-length setting is heavily influenced by the facts and circumstances. The courts look to the genuineness of the parties' intention to create a debtor-creditor relationship and to the reasonableness of that intention. This is generally determined based on the credit-worthiness of the borrower. This is done under two approaches: (i) an objective analysis of the borrower's financial conditions as of the time the loan was first made, or (ii) a subjective analysis that looks for hallmarks of a true debt.

Under the objective approach, key financial ratios are reviewed to determine if the borrower objectively fits within an independent lender's paradigm. These factors

*“Over the years, however, the U.S. courts established several factors to determine when capital investment will be treated as debt or equity.”*

---

<sup>9</sup> Federal Income Taxation of Corporations and Shareholders (Thomson Reuters/WG&L, 7th ed. 2013 with updates through March 2014) (accessed on Checkpoint ([www.checkpoint.riag.com](http://www.checkpoint.riag.com)) [4/11/14]).

include the company's earnings before interest, tax, depreciation and amortization ("E.B.I.T.D.A."), debt to equity ratio, current assets to current liabilities ratio, and E.B.I.T.D.A. to interest ratio.

Under the subjective approach the courts deemed several factors as important when a shareholder makes loans to a company. The controlling case law is *Mixson*<sup>10</sup> and it provides the following factors:

1. The names given to the certificates evidencing the indebtedness – if no documentation exists, the informality may suggest that intent to repay was not present at the time the loan came into existence;
2. The presence or absence of a fixed maturity date – the absence of a fixed maturity date may suggest that intent to repay was not present at the time the loan came into existence;
3. The source of payments – in general, a purported debt can be repaid from three possible sources: (i) the liquidation of the corporation's assets, (ii) profits and cash flow from the corporation's business, and (iii) refinancing the debt. If the only reasonably assured source of funds for repayment of the debt is the liquidation of the debtor's assets, then the investment resembles an equity investment. Conversely, a purported debt will be recognized as debt if the projected cash flow is adequate to repay the obligation;
4. Increased participation in management – if as a result of granting the loan the lender has an increased right to participate in management, this may suggest that the instrument has indicia of equity;
5. The right to enforce payment of principal and interest – although junior to a secured creditor, a general creditor typically has rights to enforce repayment on demand. Lacking this right may suggest indicia of equity;
6. The intent of the parties – in seeking the intent, focus is placed on how the parties treated the instrument. While not conclusive, a relevant consideration in addition to the preceding factors includes the accounting treatment of the loan on the company's books;
7. "Thin" or inadequate capitalization – the adequacy of a borrower's capital structure at the onset of the purported debtor-creditor relationship may indicate the creditor's intent to be repaid in accordance with the terms of the instrument. The equity capitalization provides a cushion to protect the creditor from the borrower's business losses and a decrease in the value of its assets. Thus, inadequate capitalization at the time the relationship was established may be an indication of whether or not a reasonable expectation of repayment existed;<sup>11</sup>

---

<sup>10</sup> *Estate of Mixon v. U.S.*, 464 F.2d 394, 402 (5th Cir. Ala. 1972).

<sup>11</sup> The withdrawn proposed regulations under Code §385 provided a safe harbor rule which would have assured debt classification if the total debt-to-equity ratio

8. Identity of interest between creditor and stockholder – if debt is provided by stockholders in proportion to their respective stock ownership, it may indicate that the investment is an equity contribution;
9. Interest payments – the lack of provisions for the payment of interest indicates that the funds loaned were intended as a contribution to equity rather than an arm's-length debt obligation. The failure to insist on interest payments ordinarily indicates that the lender is not expecting interest income but is interested in the future earnings of the corporation or the increased market value of its interest;
10. The ability of the corporation to obtain loans from outside lending institutions – if a corporation is able to borrow funds from outside sources, the shareholder loan would appear to be a bona fide indebtedness;
11. The extent to which the loan was used to acquire capital assets – courts have held that purported debt should be treated as equity if the funds advanced are used to acquire the essential assets of a business;<sup>12</sup> and
12. The failure of the debtor to repay on the due date or to seek a postponement – repayment of the loan under its terms and conditions is an indication of a true debt instrument.

## RECENT CASE LAW

In the last five years, the I.R.S. has begun to focus on the debt-versus-equity issue. It is said to be in dispute in many of the Large Business and International Division's cases. New decisions on debt-to-equity cases were recently issued. Two cases in which the taxpayer prevailed are: *ScottishPower*,<sup>13</sup> which resulted in debt treatment, and *PepsiCo*,<sup>14</sup> which resulted in equity treatment.

In *ScottishPower*, ScottishPower plc ("ScottishPower"), a U.K. company, entered into negotiations to acquire PacifiCorp & Subsidiaries ("PacifiCorp"), a publicly held U.S. utility company with domestic and foreign subsidiaries. To affect the acquisition, ScottishPower organized NA General Partnership ("NAGP"), which elected to be treated as a U.S. corporation. NAGP formed a special purpose subsidiary to merge into PacifiCorp. Shareholders of PacifiCorp received either ScottishPower shares or depositary shares ("ADS shares") in exchange for their

*"In the last five years, the I.R.S. has begun to focus on the debt-versus-equity issue. It is said to be in dispute in many of the Large Business and International Division's cases."*

---

(including both outside and inside debt) did not exceed 10:1 and if the inside debt-to-equity ratio did not exceed 3:1 at the end of the taxable year in which the purported debt instrument was issued.

<sup>12</sup> Since most real estate holding corporations incur mortgage debt that can only be paid at maturity by selling (or refinancing) the assets, it seems that financing the entity with a loan is a standard practice of the real estate industry and a legitimate business reason, which should not, on its own, affect the characterization of the investment as debt or equity.

<sup>13</sup> *NA General Partnership and Subsidiaries v. Commissioner*, T.C. Memo. 2012-172 (6/19/12).

<sup>14</sup> *PepsiCo Puerto Rico, Inc. v. Commissioner*, T.C. Memo. 2012-269 (9/20/12).

PacifiCorp shares. NAGP issued notes to ScottishPower in consideration for the transfer of its ADS shares and common shares (on behalf of NAGP) to PacifiCorp shareholders in connection with the merger (representing 75% of the acquisition value of PacifiCorp). The loan notes consisted of \$4 billion of fixed-rate notes and \$896 million of floating-rate notes. The fixed and floating rate notes were issued under separate loan agreements and generally contained identical terms, other than the date of maturity and the interest rates. The notes: (i) called for quarterly interest payments, (ii) were secured by a pledge of PacifiCorp shares, (iii) were transferrable, (iv) gave the creditor the right to accelerate the notes upon default, and (v) were recorded as debt on the books and records of both parties. At the time the notes were executed, the creditor, ScottishPower, expected that PacifiCorp dividends would fund the borrower's (NAGP's) interest payments. NAGP did not always pay interest on time but eventually repaid all interest. The I.R.S. argued that ScottishPower's investment in NAGP was not debt but equity.

The Tax Court ruled in favor of the taxpayer based on an analysis of the eleven factors used by the Court of Appeals for the Ninth Circuit (to which an appeal would lie). These factors comprise: (1) the name given to the documents evidencing the indebtedness, (2) the presence of a fixed maturity date, (3) the source of the payments, (4) the right to enforce payments of principal and interest, (5) participation in management, (6) a status equal to or inferior to that of regular corporate creditors, (7) the intent of the parties, (8) "thin" or adequate capitalization, (9) identity of interest between creditor and stockholder, (10) payment of interest only out of "dividend" money, and (11) the corporation's ability to obtain loans from outside lending institutions. The Tax Court noted that no one factor is decisive. The Tax Court's stated objective was not to count the factors, but rather to evaluate them. In holding for the taxpayer, the Tax Court found:

We recognize that there are features in this case pointing to both debt and equity. Nevertheless, in view of the record as a whole, we find that the advance was more akin to debt than equity. We did not rely on any single overriding factor. Rather, we find that the whole of this case is more reflective of the true relationship between the parties than the individual parts. We therefore hold that the payments of interest made with the respect to the loan notes are deductible as interest for each year at issue.

In *PepsiCo*, PepsiCo Global Investments ("PGI"), a Dutch affiliate of PepsiCo, Inc. ("PepsiCo"), issued so-called "advance agreements" to several PepsiCo domestic subsidiaries in exchange for certain outstanding indebtedness of PepsiCo and members of its consolidated group (the "Indebtedness"). PepsiCo intended the advance agreements to be treated as equity for U.S. tax purposes and as debt for Dutch tax purposes. In other words, the interest income on the Indebtedness would be offset for Dutch income tax purposes by an interest expense deduction with respect to the preferred return payable to the U.S. affiliates on the advance payments. The terms of the advance agreements were 40 years maturity with PGI's option to extend maturity date for up to 15 additional years. However, PGI had the right to prepay principal amount and preferred return in full or in part at any time. The terms also provided for a preferred return that accrued unconditionally at a defined rate, payable on an annual basis out of cash flow with respect to the Indebtedness. Any accrued but unpaid preferred return would be capitalized and accrue compound interest. Lastly, the holder of an advance agreement was subordinated to all other creditors.



The I.R.S. contended that the advance agreements were in substance debt and that the parties' intention was demonstrated in their negotiations with the Dutch tax authorities to receive a ruling that the agreements be treated as debt for Dutch purposes. The I.R.S. also argued that the terms of the agreements were not relevant because of the common control of the parties. The Tax Court ruled in favor of the taxpayer, stating that the form of a transaction often informs its substance. It explained that the characterization of the advance agreements as debt or equity must be considered by examining the relevant terms of the instruments in light of the surrounding facts and circumstances, including but not exclusive to the taxpayers' correspondence with the Dutch tax authorities, and that while the relatedness of the parties needs to be considered as a factor and closely scrutinized for substance, an otherwise legitimate transaction will not be disregarded merely because it represents a related party agreement.

The Tax Court followed a traditional analysis of the debt-versus-equity factors, listing thirteen factors: (1) names or labels given to the instruments, (2) presence or absence of a fixed maturity date, (3) source of payments, (4) right to enforce payments, (5) participation in management as a result of the advances, (6) status of the advances in relation to regular corporate creditors, (7) intent of the parties, (8) identity of interest between creditor and stockholder, (9) "thinness" of capital structure in relation to debt, (10) ability of the corporation to obtain credit from outside sources, (11) use to which advances were put, (12) failure of debtor to repay, and (13) risk involved in making advances. It concluded that the focus of a debt-versus-equity inquiry is generally whether there was intent to create a debt with a reasonable expectation of repayment and, if so, whether that intent comports with the economic reality of creating a debtor-creditor relationship. The Tax Court found that PGI was exposed to eastern European and other developing countries' markets and that together with its ability to defer repaying the principal for up to 55 years, there was no expectation of repayment.

Despite the fact that the payment of preferred return was linked to interest payments received on the indebtedness and that the Dutch tax authorities characterized the instrument as a debt instrument, the Tax Court held that the advance payments were equity. Pointing toward equity treatment was the complete subordination of the advance agreements and the finding that an independent creditor would not have loaned funds in the amount of the advance agreements to PGI under any reasonably similar financial terms. Those factors, together with the lack of repayment expectation, led the Tax Court to the conclusion that the risk involved in making the advances revealed its equity characteristics.

## CONCLUSIONS

Using indebtedness as part of a U.S. subsidiary's capital structure is often advisable from a tax point of view. In determining the capital structure of the U.S. subsidiary, it is important that the factors described above are considered carefully. Taxpayers should prepare supporting documentation to demonstrate to the taxing authorities and the courts that under an analysis of the factors, a debt instrument should be characterized as debt for U.S. tax purposes in case of an I.R.S. challenge.

*"Using indebtedness as part of a U.S. subsidiary's capital structure is often advisable from a tax point of view."*



# CORPORATE MATTERS: SHAREHOLDER AGREEMENTS

## Author

Simon H. Prisk

## Tags

Corporate Law  
Shareholder Agreements

In the first issue of our publication, we discussed the need and relative ease of preparing and entering into an agreement between partners and the consequences of not doing so. We used the recent case of *Gelman v. Buehler* 2013 NY Slip OP 01991 (March 26, 2013) to illustrate the sometimes expensive consequences of not documenting the initial agreements between partners. Following up on that, we thought it might be helpful to outline in broad terms what one should look for in a shareholders agreement.

While we have stated that it is relatively simple to prepare a shareholders agreement. Careful consideration still must be given to the contents of such an agreement, and it should be tailored to meet the needs of the parties involved. No two shareholders agreements are alike, and one size definitely does not fit all.

When one thinks of a shareholders agreement it is typically in the context of a corporation. Many of the same issues arise between partners when drafting a partnership agreement and members in a limited liability company operating agreement.

## SHAREHOLDERS

All of the shareholders should be correctly named and their percentage ownership in the entity set forth. All shareholders that are entities should be in good standing, and individuals should have their complete address inserted.

## CAPITAL CONTRIBUTIONS

The amount of capital or the value of assets contributed should be clearly stated. If all of the capital is not to be contributed at signing, a time-line should be established with penalties for failure to contribute on a timely basis. If it is anticipated that additional capital may be required to fund the venture's operations, it is necessary for the mechanism surrounding capital calls and payments of additional capital to be set out in the agreement. If a shareholder fails to make an additional capital contribution when required, the agreement may provide for the deficit to be made up by the non-defaulting shareholder(s) by way of a capital contribution in excess of their pro rata obligation, with a corresponding adjusting in the equity of the entity, or by loans to the entity by the non-defaulting shareholder(s).

## MANAGEMENT

In a closely held entity, the shareholders may control the day-to-day management themselves. In any management structure, a shareholder will ideally have some control over major decisions. A super majority vote may be desired for certain corporate actions. The list could include any of the following:

- Issuance of further share capital;
- Decision to require additional capital contributions;
- Entry into other areas of business;
- Amendments to shareholders agreement;
- Any action relating to the merger, sale or reorganization of the entity;
- Incurrence of debt above a certain level;
- Appointment or removal of auditors;
- Approval of annual budget; or
- Any decision to distribute cash or other assets of the entity.

## TRANSFER

A shareholder may request preemptive rights in the event the entity desires to issue more stock. The agreement will typically give a right of first refusal to other shareholders in the event of a proposed sale and may include drag-along rights<sup>15</sup> at the request of a major shareholder or tag-along rights<sup>16</sup> at the request of minority holders. With first refusal rights, any stock proposed to be sold by a shareholder must first be offered to existing shareholders on a pro rata basis. While this right allows shareholders to maintain their existing ownership percentages, it does slow down the process of selling shares and is not favored by certain investors when considering an investment.

---

<sup>15</sup> This is a right that enables a majority shareholder to force a minority shareholder to join the sale of a company, provided that the minority shareholder receives the same terms as any other shareholder.

<sup>16</sup> This is the opposite of drag along rights and allows the minority shareholder to “tag along” or join the transaction.

## NON-COMPETE

It may be important to prevent any shareholder from competing with the business of the entity and agreeing that the entity is the only vehicle through which any shareholder will conduct such a business.

## DISPUTE RESOLUTION

Arbitration is typically a less expensive way to settle disputes than court proceedings. Consideration may also be given to a mediation clause where an individual agreeable to the parties is selected to settle disputes.

Shotgun Buy/Sell provisions are useful in the event of continued disputes between the parties. One party can make an offer to buy the entity, and the party receiving the offer can then elect to be a buyer or a seller on the terms offered. This clause favors the party with the deepest pockets.

## DEATH OR DISABILITY

When a shareholder dies all shares owned become part of the deceased's estate, and therefore, will pass on to the deceased's heirs. In a closely held organization, it is probably not a good idea to end up with a partner's relatives as your business partners. Every shareholder agreement should include a clause allowing the buyout of a partner's estate. It is not necessary to provide for the purchase of all of the interest held by the deceased, as most individuals will want their estate to participate in the growth of the business after they die. Consider a provision that provides for the purchase of most, but not all, of the interest, say 75%, with the remaining shares converting to non-voting shares. The same principle applies to disability of a shareholder, and care should be given to how disability is defined.

## TAX

As noted in our last issue,<sup>17</sup> in general, corporations are subject to an entity level of tax. To the extent dividends are paid, that shareholder will be subject to tax on the dividends received. In the case of a non-U.S. person, the tax may be withheld at the source but reduced by an applicable treaty. However, a Corporation may elect "S Corporation" status and "pass through" corporate income and losses to its shareholders. However, shareholders must be U.S. citizens or U.S. residents, among other limitations. Additionally, non-U.S. shareholders should determine how their interest in the U.S. entity is treated (or taxed) in their home jurisdiction and whether another type of entity (e.g., LLC or partnership) or another type of capital structure (e.g., debt v. equity), is a more appropriate conduit or a more efficient (tax) structure for their investment. As there may be competing interests amongst

*"...non-U.S. shareholders should determine how their interest in the U.S. entity is treated (or taxed) in their home jurisdiction..."*

---

<sup>17</sup>

See [Insights, Vol. 1, No. 2.](#)

shareholders, drafting a proper agreement, and/or agreeing to basic terms and structures, is essential for efficient corporate and tax planning.

## CONCLUSION

As noted in our prior issue, a well drafted agreement may significantly reduce the chances and expenses of litigation in the case of a disagreement. Thus, importance should be placed on identifying issues and drafting them away at the start at the deal, transaction, business venture, or partnership. We are here to assist.



# NEW YORK STATE MAKES MAJOR CHANGES TO ESTATE AND GIFT TAX LAW

## Authors

Nina Krauthamer  
and Kenneth Lobo

## Tags

New York Estate and Gift Tax

**New Exclusion Amount:** Prior to April 1, 2014, an estate was required to file a New York State estate tax return if the total of the federal gross estate plus the federal adjusted taxable gifts and specific exemption exceeded \$1 million (the “basic exclusion amount”) and the individual was either: (i) a resident of the state at the time of death or (ii) a resident or citizen of the U.S. at the time of death but not a resident of the state, whose estate includes real or tangible personal property located in the state. (Other rules apply to individuals who were not residents or citizens of the U.S., but who died owning real or tangible personal property located in the state.)

Recent N.Y.S. legislation has increased the basic exclusion amount as follows:

- For individuals dying on or after April 1, 2014 and before April 1, 2015 - \$2,062,500
- For individuals dying on or after April 1, 2015 and before April 1, 2016 - \$3,125,000
- For individuals dying on or after April 1, 2016 and before April 1, 2017 - \$4,187,500
- For individuals dying on or after April 1, 2017 and before January 1, 2019 - \$5,250,000

After January 1, 2019, the basic exclusion amount will be indexed for inflation from 2010, which should link the state exclusion amount to the federal amount.

**Estate Tax “Cliff.”** The basic exclusion amount is not a true exclusion, but rather an estate tax “cliff.” The basic exclusion amount equates to an applicable credit amount. For New York taxable estates that are between 100% and 105% of the basic exclusion amount, the credit amount is rapidly phased out and *eliminated entirely* if the New York taxable estate exceeds 105% of the basic exclusion amount. Therefore, if a resident decedent’s taxable estate exceeds the basic exclusion amount by more than 5%, the *entire* taxable estate will be to be subject to New York estate tax.

**No Change to Top Estate Tax Rate.** The top estate rate remains 16%.

**No Portability.** The New York State legislation did not include Federal “portability” whereby the executor of the deceased spouse can elect to transfer the deceased spouse’s unused applicable exclusion amount to the surviving spouse.

**Gift Add Back.** Prior to the law change, there was no gift tax in New York and no additional estate tax on gifts although the amount of lifetime taxable gifts made by a New Yorker may have caused the estate tax rate to increase. Under the new law, the New York gross estate of a resident decedent will be increased by the amount of any taxable gifts for federal gift tax purposes (not otherwise included in the decedent's federal gross estate) made during the three-year period ending on the decedent's date of death, but not including any gift made: (1) when the decedent was not a resident of New York State; (2) before April 1, 2014; or (3) on or after January 1, 2019.

**Throwback/Accumulation Tax.** Accumulation distributions (limited to undistributed net income accumulated in a taxable year commencing after December 31, 2013) by exempt resident trusts, generally not subject to New York tax, to New York beneficiaries will be subject to an accumulation tax. An exempt resident trust is a trust created by a New York domiciliary that has no trustee domiciled in New York, no trust property located in New York and no New York source income. These changes would be effective immediately and will be applicable to tax years beginning on or after January 1, 2014. The tax will not be imposed on distributions of accumulated income by exempt resident trusts (except ING trusts) made before June 1, 2014. Nonresident trusts are not subject to this tax.

**ING Trusts.** Incomplete gift, nongrantor trusts ("ING Trusts"), which had received favorable federal private letter rulings, had been established to minimize state taxes. The ING Trust is established in a jurisdiction, such as Delaware, that does not impose a state fiduciary income tax and does not tax distributions to out-of-state beneficiaries. Further, neither the trust nor its beneficiaries would normally be subject to state income tax in the beneficiaries' state of domicile on either the income or distributions of an out-of-state nongrantor trust. The new law now subjects ING Trusts to New York income tax by treating those trusts as grantor trusts for New York income tax purposes. This change would be effective immediately and be applicable to tax years beginning on or after January 1, 2014. Income earned by ING trusts that are liquidated on or before June 1, 2014 is not subject to tax.



# U.S. TAX TREATY UPDATE

## Authors

Kenneth Lobo  
and Nina Krauthamer

## Tags

Tax Treaties

At a business meeting on April 1, 2014, the Senate Foreign Relations committee approved two proposed treaties with Hungary and Chile, tax treaty amendments (“protocols”) with Switzerland and Luxembourg, and a protocol amending the Multilateral Convention on Mutual Administrative Assistance in Tax Matters.

As in recent years, improved information sharing and limitations on “treaty shopping” (the inappropriate use of a tax treaty by residents of a third country) continue to be important U.S. objectives.

Highlights of the approved measures include the following:

- The proposed treaty between Hungary and the U.S. encompasses a comprehensive “Limitation on Benefits” provision, unlike the current treaty with Hungary, of 1979, which contains no such limitation, and also provides for a full exchange of information. The new Limitation on Benefits provision includes a measure granting so-called “derivative benefits” similar to the provision included in all recent U.S. tax treaties with European Union members.
- The proposed treaty between Chile and the U.S. would be the first income tax treaty between the two countries and only the second treaty with a South American country. The treaty contains comprehensive limitations on benefits provisions and full exchange of information.
- The Swiss protocol would update tax information exchange provisions consistent with current U.S. tax treaty practice. The Swiss tax authorities would be allowed to exchange information otherwise subject to bank secrecy laws in Switzerland.
- The Luxembourg protocol has similar objectives. The U.S. would be allowed to obtain information from Luxembourg, whether or not Luxembourg requires the information for its own tax purposes. The request for information cannot be denied solely because the information is held by a bank or financial institution. Further, the proposed change also states that information can be exchanged without regard to whether the conduct being investigated would be a crime under the laws of the requested State.
- A third protocol amends the O.E.C.D.’s 1988 Multilateral Convention on Mutual Administrative Assistance in Tax Matters to update information exchange and confidentiality rules and opens the convention to countries outside the O.E.C.D. and Council of Europe.

## UPDATES AND OTHER TIDBITS

### Authors

Alev Fanny Karaman  
and Cheryl Magat

### Tags

Dividend Equivalents  
International Tax  
B.E.P.S.  
Virtual Currency

### CORRECTION TO THE PROPOSED 2013 DIVIDEND EQUIVALENT REGULATIONS

On December 5, 2013, proposed and final Treasury Regulations were published, relating to U.S. source dividend equivalent payments made to nonresident individuals and foreign corporations.<sup>18</sup> On February 24, 2014, a correction to the proposed regulations was published, which tackles errors contained in the 2013 proposed regulations. The corrections mainly clarify the 2013 proposed regulations and prevent any potential misleading caused by their formulation. In addition, on March 4, 2014, the I.R.S. released Notice 2014-14, which states that it will amend forthcoming regulations to provide that specified equity-linked instruments (“E.L.I.’s”) will be limited to those issued on or after 90 days following publication of the final regulations. This will allow additional time for financial markets to implement necessary changes.

### UNITED STATES AND HONG KONG SIGN T.I.E.A.

On March 25, 2014, H.K. and U.S. governments signed a Tax Information Exchange Agreement (“T.I.E.A.”) confirming their commitment to enter into an I.G.A., subject to ongoing discussions. The T.I.E.A. will apply to profits tax, salaries tax, and property tax in H.K. and will cover federal taxes on income, estate and gift taxes, and excise taxes in the U.S.

### E.U. ORDERS TAX INFORMATION FROM LUXEMBOURG DETAILING PATENT BOX AND CORPORATE SCHEMES

On March 24, 2014, the European Commission demanded that Luxembourg provide information on its corporate tax arrangements with more than 100 companies, including some leading U.S. multinationals, or face legal action with the European Court of Justice. This comes after Luxembourg previously declined to provide the Commission with the information, which relates to agreements made by

---

<sup>18</sup> See our article “[Dividend Equivalents: Past, Present and Future](#)” in *Insights* Vol. 1, No.1.



rulings of the Luxembourg tax authorities in 2011 and 2012, claiming it was protected by rules on “fiscal secrecy.” Under these agreements, authorities settled (typically in confidence) the manner in which they intended to apply tax rules to a company's activities and often provided informal tax-breaks to favored multinationals. The Commission also requested details regarding “patent box” schemes that allow companies to receive tax reductions of 80% on income from intellectual property including patents, trademarks, and models as a means of support in technology. In 2013, the Commission concluded that the patent box plan in the U.K. violated E.U. Code of Conduct rules against unfair taxation; however, the U.K. was able to defer a decision to allow E.U. finance ministers to further study the issue. If the Commission finds evidence that tax breaks constituted illegal state aid, it can demand that the funds be repaid.

## SENATE RELEASES REPORT, HOLDS HEARING ON CATERPILLAR TAX STRATEGY

On April 1, 2014, executives from construction equipment manufacturer Caterpillar Inc. (“Caterpillar”) voluntarily agreed to testify before the Senate Homeland Security and Governmental Affairs Permanent Subcommittee on Investigations (“P.S.I.”) to discuss the company's offshore tax strategies. P.S.I. also released a subcommittee report detailing Caterpillar's tax strategies and international business operations.

The hearing and report relates to the year 2009, when a former Caterpillar employee, Daniel Schlicksup, sued the company, alleging that he faced reprisal from management after he raised ethical objections to Caterpillar's tax practices. (Mr. Schlicksup claimed that the tax strategy lacked economic substance and had no business purpose other than tax avoidance.) He accused the company of using a “Swiss structure” to shift profits to offshore companies and avoid more than \$2 billion in U.S. federal corporate taxes. The structure involved many shell corporations with no business operations, through which management of profitable business was technically shifted to Switzerland while actually remaining in the United States. The details of the report provide that in 1999, Caterpillar used a new series of complex transactions to designate a new Swiss affiliate, Caterpillar SARL (“CSARL”), as its “global parts purchased” and licensed CSARL to sell third-party-manufactured parts to Caterpillar's non-U.S. dealers. This strategy effectively removed Caterpillar from the legal title chain for non-U.S. parts. Caterpillar then received royalty payments, resulting in 15% or less of the profits from the sale of replacement parts, while the remaining 85% of the profits was attributed to CSARL. Furthermore, Caterpillar was able to negotiate a deal with Swiss officials in which its effective tax rate in Switzerland was between 4% and 6%, lower than Switzerland's general federal corporate tax rate of 8.5%. Schlicksup also alleged the use of a “Bermuda structure” and a “Luxembourg structure” by which shell companies returned profits to the U.S. without paying taxes in 2005. The suit was settled in 2012.

During the hearing, Caterpillar executives defended the tax strategy and even received support from Republican senators, who claimed that Caterpillar was not the problem but the result of a “broken tax code.” Among developed countries, the U.S. has the highest corporate tax rate and is one of the few remaining jurisdictions with a version of a territorial tax system. PwC, who was paid to \$55 million to develop the tax strategy and served as both tax consultant and auditor to

Caterpillar at the time, was also questioned at the Senate hearing. It stood by its structure and claims it maintained independence at all times.

The Senate report makes four recommendations:

- The I.R.S. should clarify regulations on transfer pricing transactions to analyze whether the transactions have economic substance;
- I.R.S. transfer pricing regulations should require the U.S. parent corporation to identify and value the functions of related parties participating in a transfer pricing agreement and provide justification for the profit allocation in accordance with which of the parties performed the functions that contributed to specified profits;
- The Treasury and the I.R.S. should participate in O.E.C.D. efforts to develop improved international principles for taxing multinational companies; and
- Public accounting firms should be prohibited from providing auditing and tax consulting services to the same corporation simultaneously.

## I.R.S. RELEASES VIRTUAL CURRENCY GUIDANCE

The I.R.S. released Notice 2014-21 (“Notice”) on March 25, 2014, guidance in the form of F.A.Q.’s providing basic information on the U.S. federal tax implications of transactions involving virtual currency. The Notice states that transactions involving virtual currencies, such as Bitcoin, may create a tax liability on a per transaction basis, causing a potential administrative nightmare.

The I.R.S. describes virtual currency as “a digital representation of value that functions as a medium of exchange, a unit of account, and/or a store of value.” It may function like “real” currency and is customarily used and accepted as a medium of exchange in the issuing country. However, virtual currency does not have legal tender status in any jurisdiction.

The Notice provides that virtual currency is treated as *property* for U.S. federal tax purposes, and therefore, general tax principles which apply to property transactions also apply to those transactions that involve virtual currency.<sup>19</sup> Therefore:

- It is not treated as foreign currency, and there is no exchange gain or loss.<sup>20</sup>
- For a sale or exchange, the amount of gain or loss must be calculated. Thus, a determination of basis is required and amount realized. In addition, the character of gain or loss attributed to the sale or exchange of virtual

---

<sup>19</sup> Notice 2014-21, FAQ No.1.  
<sup>20</sup> *Id.*, FAQ No.2.

currency is dependent upon whether the currency is a capital asset in the hands of the taxpayer.<sup>21</sup>

- Employee wages paid with virtual currency are taxable to the employee, must be reported on a Form W-2, and are subject to withholding and payroll taxes.<sup>22</sup> Backup withholding is obligatory in the case where there is no T.I.N. or if the payor receives notification from the I.R.S. that backup withholding is required.<sup>23</sup>
- Payments made to independent contractors and other service providers with virtual currency are also taxable under the self-employment tax rules;<sup>24</sup> generally, a Form 1099-MISC is issued by the payor, and the payment must be reported to the I.R.S. for amounts greater than \$600.<sup>25</sup>
- Any payments made using virtual currency are subject to information reporting to the same extent as any other payments made in property.<sup>26</sup>

Finally, if taxpayers do not comply with tax laws, taxpayers may be subject to penalties. For instance, if there is a failure to timely or correctly report virtual currency transactions when required to do so, the taxpayer may be subject to penalties under Code §§6721 and 6722. Penalty relief may be available to taxpayers and persons required to file an information return who are able to establish that the underpayment or failure to file returns is due to reasonable cause.<sup>27</sup>



---

<sup>21</sup> *Id.*, FAQ No. 7.  
<sup>22</sup> *Id.*, FAQ No.11.  
<sup>23</sup> *Id.*, FAQ No.14.  
<sup>24</sup> *Id.*, FAQ No. 10.  
<sup>25</sup> *Id.*, FAQ No. 13.  
<sup>26</sup> *Id.*, FAQ No. 12.  
<sup>27</sup> *Id.*, FAQ No. 16.

## IN THE NEWS

### VIDEO – A WELCOME FROM STANLEY RUCHELMAN

While attending a recent conference in Milan, founding member, Stanley C. Ruchelman, took the opportunity to sit down with G.G.I. to discuss the core practice and goals of Ruchelman P.L.L.C. The video highlights the role of cross-border tax planning in achieving a business model of economic substance and is available on the Publications page of our website, under the title [“A Welcome from Stanley Ruchelman”](#).

### A.B.A. SECTION OF TAXATION – OPTIONS FOR TAX REFORM IN THE I.R.C.

Stanley C. Ruchelman was a substantive contributor to [“Options for Tax Reform in the Inbound International Tax Provisions of the Internal Revenue Code”](#), commentary submitted to the Senate Finance and House Ways and Means Committees on December 3, 2013 by the A.B.A. Section of Taxation and published in the Winter 2014 edition of *The Tax Lawyer*. The paper proposes reforms to the Internal Revenue Code for simplification and clarification of various inbound international tax provisions, which would encourage compliance and ease unnecessary taxpayer burdens.

## OUR RECENT AND UPCOMING PRESENTATIONS

On February 11, 2014, Armin Gray participated in a panel entitled [“F.A.T.C.A. and the U.S. Canada I.G.A.”](#) at the Canada Professionals Seminars in Toronto, Canada. The panel addressed F.A.T.C.A. and the new U.S. Canada I.G.A. signed on February 5, 2014.

On March 8, 2014, Stanley C. Ruchelman participated in two panels at the G.G.I. I.T. Winter Meeting in Milan, Italy. The first panel entitled “Voluntary Disclosure of Tax Evasion” discussed transparency initiatives in various countries. The second presentation entitled “Base Erosion and Profit Shifting and the O.E.C.D.” provided an overview of the activities and objectives of the O.E.C.D. and addressed recent developments in the B.E.P.S. project.

On March 13, 2014, Edward C. Northwood presented a seminar entitled [“Cross Border Issues in Trusts & Estate Matters,”](#) organized by the Monroe County Bar Center for Education in Rochester. The presentation focused on income and estate

tax in New York State and the U.S. and summarized cross border tax planning strategies.

On March 24, 2014, Robert G. Rinninsland lectured to a group of LL.M. candidates at New York Law School. The discussion addressed transfer pricing issues arising in cross borders transactions of intellectual property.

On April 3, 2014, Galia Antebi presented a seminar entitled "Three Traps in Sending Client or Funds to the U.S." at the G.G.I. European Conference in Edinburgh. The discussion included the green card trap, foreign gifts and foreign trusts.

On April 10, 2014, Stanley C. Ruchelman participated in a panel entitled "New Information Changes and Reporting Challenges for the Swiss Financial Sector" at the 14th Annual Tax Planning Strategies - U.S. and Europe Conference in Geneva. The panel addressed the impact of O.E.C.D., G20, and F.A.T.C.A. tax regimes on the Swiss financial environment and provided practical advice on current compliance challenges.

On April 30, 2014, Philip Hirschfeld will participate in a panel entitled "F.A.T.C.A. for Those on This Side of the Ocean/Border" for an A.B.A. Section of Taxation Webinar. The discussion will follow up on a January F.A.T.C.A. panel held at the A.B.A. Winter Meeting in Phoenix, but with the addition of late-breaking F.A.T.C.A. developments and the participation of two members of the I.R.S. Office of Chief Counsel.

A copy of our presentations is available on our website: [www.ruchelaw.com/publications](http://www.ruchelaw.com/publications) or by clicking the above links.

## About Us

We provide a wide range of tax planning and legal services for foreign companies operating in the U.S., foreign financial institutions operating in the U.S. through branches, and U.S. companies and financial institutions operating abroad. The core practice of the firm includes tax planning for cross-border transactions. This involves corporate tax advice under Subchapter C of the Internal Revenue Code, advice on transfer pricing matters, and representation before the I.R.S.

The private client group of the firm also advises clients on matters related to domestic and international estate planning, charitable planned giving, trust and estate administration, and executive compensation.

The tax practice is supported by our corporate group, which provides legal representation in mergers, licenses, asset acquisitions, corporate reorganizations, acquisition of real property, and estate and trust matters. The firm advises corporate tax departments on management issues arising under the Sarbanes-Oxley Act. Our law firm has offices in New York City and Toronto, Canada. More information can be found at [www.ruchelaw.com](http://www.ruchelaw.com).

## Disclaimers

This newsletter has been prepared for informational purposes only and is not intended to constitute advertising or solicitation and should not be used or taken as legal advice. Those seeking legal advice should contact a member of our law firm or legal counsel licensed in their jurisdiction. Transmission of this information is not intended to create, and receipt does not constitute, an attorney-client relationship. Confidential information should not be sent to our law firm without first communicating directly with a member of our law firm about establishing an attorney-client relationship.

## Circular 230 Notice

To ensure compliance with requirements imposed by the I.R.S., we inform you that if any advice concerning one or more U.S. Federal tax issues is contained in this publication, such advice is not intended or written to be used, and cannot be used, for the purpose of (i) avoiding penalties under the Internal Revenue Code or (ii) promoting, marketing, or recommending to another party any transaction or matter addressed herein.

## Contacts

If you have any questions about this newsletter, please contact the authors of this newsletter or any one of the following members.

### **NEW YORK**

---

Stanley C. Ruchelman	<a href="mailto:ruchelman@ruchelaw.com">ruchelman@ruchelaw.com</a>	+1. 212.755.3333 x 111
----------------------	--	------------------------

---

Robert G. Rinnisland	<a href="mailto:rinnisland@ruchelaw.com">rinnisland@ruchelaw.com</a>	+1. 212.755.3333 x 121
----------------------	--	------------------------

---

Nina Krauthamer	<a href="mailto:krauthamer@ruchelaw.com">krauthamer@ruchelaw.com</a>	+1. 212.755.3333 x 118
-----------------	--	------------------------

---

Simon H. Prisk	<a href="mailto:prisk@ruchelaw.com">prisk@ruchelaw.com</a>	+1. 212.755.3333 x 114
----------------	--	------------------------

---

Andrew P. Mitchel	<a href="mailto:mitchel@ruchelaw.com">mitchel@ruchelaw.com</a>	+1. 212.755.3333 x 122
-------------------	--	------------------------

---

Armin Gray	<a href="mailto:gray@ruchelaw.com">gray@ruchelaw.com</a>	+1. 212.755.3333 x 117
------------	--	------------------------

---

Philip Hirschfeld	<a href="mailto:hirschfeld@ruchelaw.com">hirschfeld@ruchelaw.com</a>	+1. 212.755.3333 x 112
-------------------	--	------------------------

---

Galia Antebi	<a href="mailto:antebi@ruchelaw.com">antebi@ruchelaw.com</a>	+1. 212.755.3333 x 113
--------------	--	------------------------

---

Alev Fanny Karaman	<a href="mailto:karaman@ruchelaw.com">karaman@ruchelaw.com</a>	+1. 212.755.3333 x 116
--------------------	--	------------------------

---

Kyu Kim	<a href="mailto:kim@ruchelaw.com">kim@ruchelaw.com</a>	+1 212 755 3333 x 125
---------	--	-----------------------

---

Jennifer Lapper	<a href="mailto:lapper@ruchelaw.com">lapper@ruchelaw.com</a>	+1. 212-755-3333 x 124
-----------------	--	------------------------

### **TORONTO**

---

Edward C. Northwood	<a href="mailto:northwood@ruchelaw.com">northwood@ruchelaw.com</a>	+1. 416.350.2026
---------------------	--	------------------

---

Ken Lobo	<a href="mailto:lobo@ruchelaw.com">lobo@ruchelaw.com</a>	+1. 416.644.0432
----------	--	------------------

## Editors

Stanley C. Ruchelman  
Armin Gray  
Jennifer Lapper

## Design Team

Kyu Kim  
\*Photos used in this issue were taken by Joan Ruchelman at The Louvre Museum in Paris, France, and edited by Kyu Kim